

ULTIMATE

220 & 340

Instantaneous Indirect Water Heater

By Dunkirk Boilers

- INSTALLATION AND OPERATING INSTRUCTIONS
- ENGINEERING MANUAL

Manufacturer's Warning

To reduce the possibility of injury due to scalding, a thermostatic mixing valve should be installed on all installations. Failure to do so will result in domestic water being delivered to the faucets at a temperature equivalent to the boiler water.

All commercial installations requiring sustained water temperatures beyond 120°F, must label all fixtures alerting water users of a potential scalding hazard.

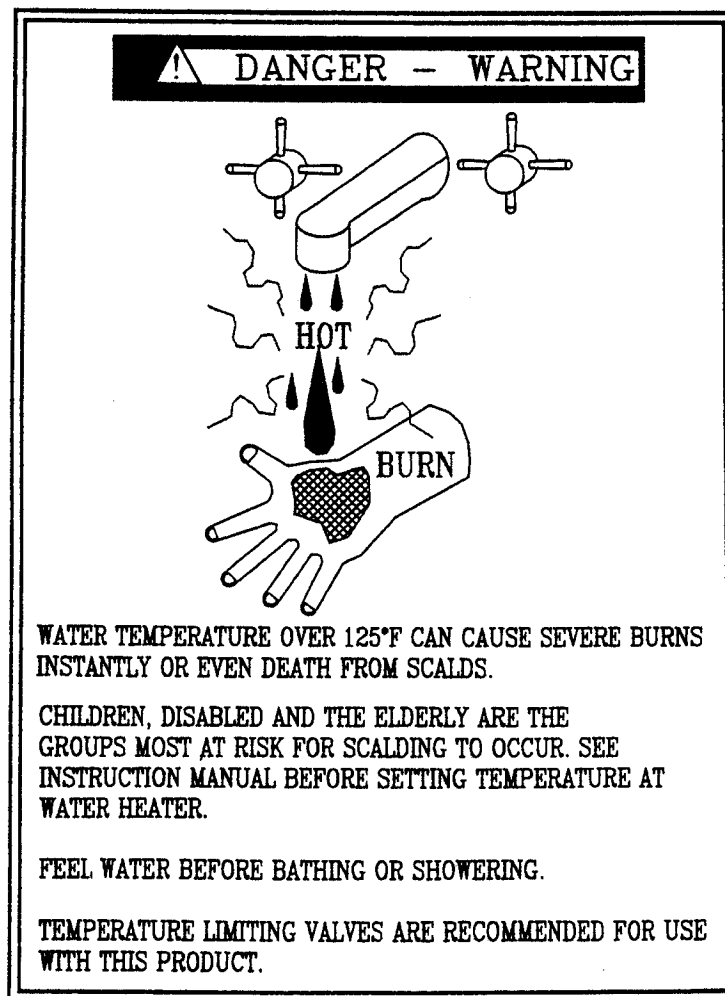

CONTENTS	pg
I. Product Description.....	4
II. Specifications	4
III. Sizing A Water Heater For Installation.....	7
Method A - Quick Residential.....	8
Method B - Detailed Residential.....	g
Method C - Commercial.....	13
IV. Before Starting Installation	19
V. Locating the Water heater.....	19
VI. Piping	20
Zone Design	
Boiler Side Piping	21
Domestic Piping	29
VII. Wiring.....	33
VIII. Start-up and Check-out.....	40
Appendix A	40

I. Product Description

The Indirect water heater is designed to generate domestic hot water in conjunction with a hot water boiler using forced boiler water circulation. This indirect water heater consists of a plain steel tank in which three smooth copper coils are located. The tank surrounded by 2" of Poly - urethane foam insulation, which is surrounded by an enamel coated plain steel jacket.

The boiler water pumps through the tank and heats the domestic water in the coils.

Specifications

TABLE 1: — Performance (Per the Hydronics Institute Draft Proposed Standard for Testing Indirect Water Heaters)

Required Boiler Output (Heating Capacity)	Flow Rating, Gal/hr at 140°F (90°Δ T)		Flow Rating Gal/hr at 110°F (60°Δ T)		Min. Boiler Water Flow Gal/min
	MBH	First Hour	Continuous	First Hour	
WATER HEATER Model 220					
50	78	72	117	108	2.7
70	102	95	153	142	2.7
90	129	120	193	180	2.7
110	156	147	233	220	3.4
140	195	187	292	280	5.4
160	220	213	330	320	6.5
WATER HEATER Model 340					
160	226	213	339	320	4.1
190	265	253	398	380	5.7
220	305	294	456	440	6.7
250	343	333	566	550	9.0
300	369	360	557	540	10
350	428	420	648	630	12.5
400	487	480	739	720	15.0
<p>Conditions: 50°F domestic water in, and 180°F boiler water in. Model 220 the max pressure drop of domestic water is 4 psi. The maximum boiler water (tank) pressure drop at rated flow is less than ¼ ft. of head. Model 340 – see tables 1a & 1b.</p> <p>Pressure Ratings: Maximum Allowable Tank Working Pressure – 150 psi</p>					

TABLE 1a: — Pressure drop through the Artesian 340 (boiler water)

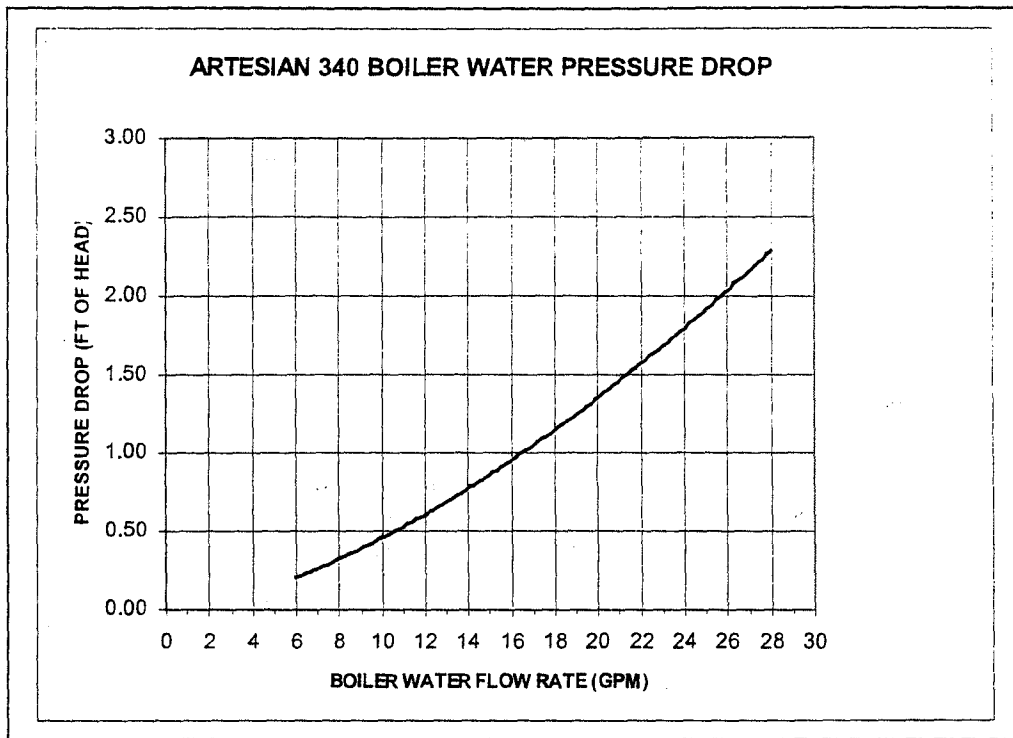
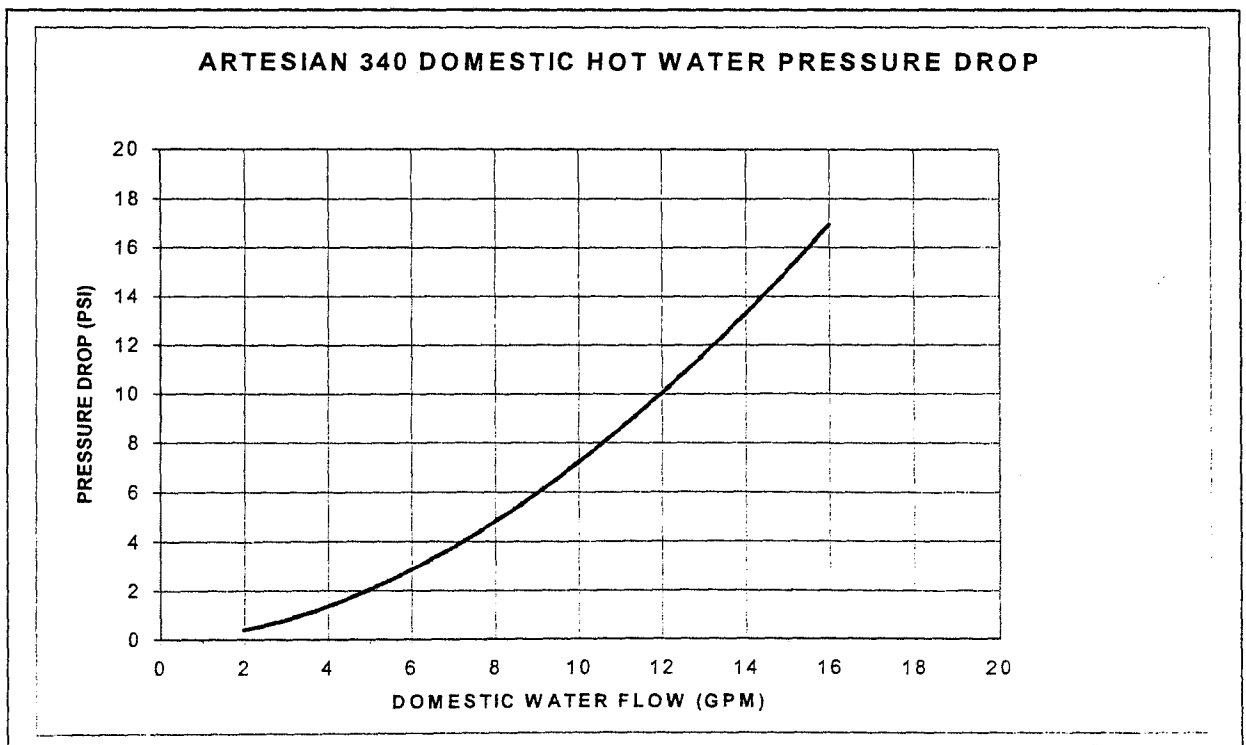

TABLE 1b: — Pressure drop through the Artesian 340 (domestic water)



II. Specifications Continued
Figure 1

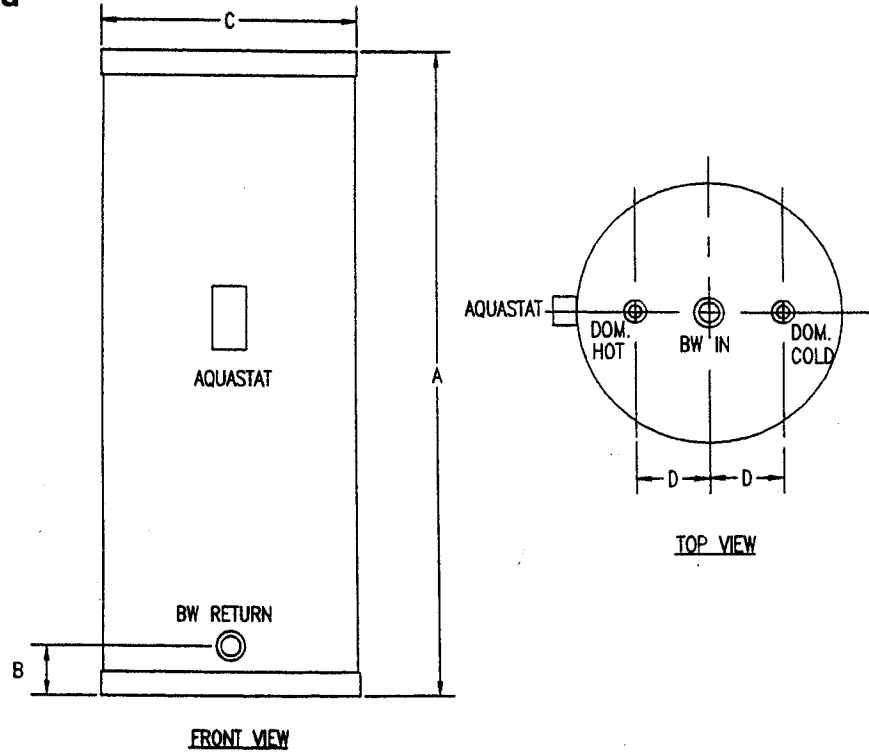

TABLE 2: Physical Specifications

Model	A	B	C	D	Coil Surface (Sq. Ft.)	Weight		Boiler Water Content in Tank U.S. Gal.
						Net lbs	Full lbs	
MODEL 220	39.4"	4.5"	18.06"	3.25"	17	117	269	20
MODEL 340	46.4"	4.5"	18.06"	3.25"	20	141	357	26

TABLE 3: Connections

Key	Description	MODEL 220 & 340
DOM COLD	Cold Domestic Water Inlet To Boiler Return From Boiler Supply Hot Domestic Water Out Aquastat Tapping	3/4 NPT (F)
BW RETURN		1-1/4 NPT (F)
BW IN		1-1/4 NPT (F)
DOM HOT		3/4 NPT (F)
AQUASTAT		3/4 NPT (F)

III. Sizing The Hot Water Heater For Installation

IMPORTANT

The following procedures are used to size indirect water heaters based on the amount of hot water required during a given hour. In doing so, it is assumed that this demand will be spread out over the course of the entire hour.

THESE SIZING PROCEDURES ARE PROVIDED AS A GUIDE TO ASSIST THE PROFESSIONAL CONTRACTOR IN SIZING THE WATER HEATER. BECAUSE OF THE LARGE VARIETY OF DEMAND SITUATIONS ENCOUNTERED IN THE FIELD, THE MANUFACTURER CANNOT GUARANTEE THE SUITABILITY OF THESE PROCEDURES TO ALL INSTALLATIONS.

To properly apply the water heater to a particular system, the following 3 steps must be done:

- 1) Determine the domestic hot water requirements
- 2) Select the correct water heater/ boiler combination
- 3) Select a pump, zone piping size, and control system to provide proper water flow from the boiler through the water heater tank.

This manual presents three methods of sizing this water heater:

Method A: Quick Residential

Method B: Detailed Residential

Method C: Commercial

Note:

The terms gross output and heating capacity are used interchangeably in this manual. Heating Capacity is the gross output of boilers of less than 300,000 Btu/Hr input as defined by D.O.E. test procedures. Gross Output is the term generally used with boilers of greater than or equal to 300,000 Btu/Hr. input.

Method A: Quick Residential Sizing Method

Table 4 shows some typical structures under which many single residence applications can be classified. This procedure will provide satisfactory results most of the time. Where greater accuracy is desired, use Method B.

- 1) Find the description that best fits the job and select the Water heater called for. Also, note the required boiler output under column (F).
- 2) The Water heater must be installed with a boiler having a gross output (DOE heating capacity) greater than or equal to that shown in column (F) of Table 4. If the Water heater is to be used with a boiler having a gross output less than that shown in table 4, use Method B.

If a boiler is to be installed with a water heater, first find a boiler, which will handle the space-heating load alone. If this boiler has a DOE heating Capacity greater than that shown in column (F) of table 4, do not add anything to the boiler selected for the Artesian.

If the boiler required for space heating alone has a DOE heating capacity less than that called for in column (F) of table 4, increase the size of the boiler selected to one with a DOE heating capacity greater than or equal to that show in column (F).

- 3) See figures 5-7 for more information on designing a water heater zone system. It is recommended that the zone be given priority.

TABLE: 4 Quick Sizing Table

	(A)	(B)	(C)	(D)	(E)	(F)
Description	Occupants	Baths	Dishwasher	Clothes Washer	Water heater Model 220	Required Heating Capacity (Btu / Hr)
Efficiency Apartment	1	1	No	No	220	90,000
Small Office	<10	1/2-1*	No	No	220	90,000
Apartment or Small House	1-3	1-1 1/2	No	Yes	220	110,000
House	1-3	1-1 1/2	Yes	Yes	220	140,000
House	3-5	2-2 1/2	Yes	Yes	220	160,000

* No Showers

Method B Detailed Residential Sizing Method Directions

- 1) Record the total number of each type to fixture in column (c) of worksheet 1. A shower head is installed over a bathtub, count both the bathtub and shower head although only one fixture will be used at a time.**
- 2) For each line, multiply the quantity entered in column (c) by the corresponding number in column (b). Enter the result in column (d).**
- 3) Total column (d). This is the PEAK HOUR DEMAND**
- 4) Multiply the Peak Hour Demand by 1.20. This is the adjusted peak hour demand**
- 5) Select the water heater based on:**
 - a) If a new boiler is to be installed with the Artesian:**
 - * Go to table 1 and select a water heater which has a 140°F first hour rating greater than or equal to the adjusted peak hour demand calculated on work sheet 1.**
 - * Refer to required boiler output in Table 1. Record the required boiler output (heating capacity) for the selected water heater in your work sheet.**
 - * Determine the boiler required to satisfy the space heating requirement alone by multiplying the space heating load by 1.15. Record this, as the boiler heating capacity required for space heating in your work sheet.**
 - * Select the boiler with the larger of the above two heating capacities.**
 - b) If the water heater is to be installed with an existing boiler:**
 - * Go to table 1 and select a water heater which has a 140°F first hour rating greater than or equal to the adjusted peak hour demand calculated above.**

If the required boiler output for the selected water heater is greater than the heating capacity of the existing boiler; the existing boiler is too small.
- 6) If a Whirlpool is on the job, see Appendix A.**
- 7) Designing the water heater zone system. Refer to Table 1 for minimum boiler water flow, and circulator sizing. For further information on zone systems refer to figures 4-9.**

**Method B – Detailed Residential Sizing Method
Work sheet 1**

Sizing Sheet: Single Family Residence

(a)	(b)	(c)	(d)
Description	140°F Water Per Fixture (Gal.)	Total Number Of Fixtures	Total (Gal)
Shower:			
(3 GPM Head)	21.0	X	=
(5 GPM Head)	35.0	X	=
(7 GPM Head)	49.0	X	=
Bath (30 Gal. Tub)	21.0	X	=
Vanity	2.8	X	=
Clothes Washer	48.0	X	=
Dishwasher	15.0	X	=
Kitchen Sink or Utility Tub	10.0	X	=
Peak Hour Demand = Total Column (d)			=
Peak Hour Demand x 1.20 = Adjusted Peak Hour Demand			=
1) Boiler Heating Capacity Required for selected water heater			= _____ BTU/hr
2) Boiler Heating Capacity Required for Space Heating (Heat Loss x 1.15)			= _____ BTU/hr

Select a boiler with a Heating Capacity greater than or equal to (1) or (2), whichever is greater.

Note: This worksheet is based on the following assumptions:
a) Ten-minute shower per shower head per hour
b) All other fixtures are used once during the hour.

Method B - Detailed Residential Sizing Sample Calculations

Example 1

A water heater is to be installed with a new boiler. The residence has the following fixtures: **Bath**

#1

3 GPM Shower Head

30 Gal. Bathtub

Vanity

Kitchen

Kitchen Sink

Automatic Dishwasher

Bath #2

Vanity

Laundry

Clothes Washer

The heat loss of the house is 80,000 BTU/hr

Note:

Although a four section boiler would be capable of heating the house (Net Rating = 82,000 BTU/hr), its DOE heating capacity is only 94,000 BTU/hr (Need 110,000 Btu/hr). For this reason, install a five section boiler that has a heating capacity of 125,000 BTU/hr.

Solution:

The completed sizing sheet for this example is shown in figure 2. The adjusted peak hour demand is 145 gallons per hour. From table 1, we see that a water heater 220 will fulfill this requirement with the appropriate boiler. Refer to Table 1 for required boiler output. If the model 220 is used in combination with a boiler capable of producing 110,000 Btu / hr. The output will give you 156 GPH first hour ratings. The circulator on the boiler must be capable of producing 3.4 GPM.

FIGURE 2:
Use of worksheet 1

Method B Example 1 Single Family Residence

(a)	(b)		(c)		(d)
Description	140°F Water Per Fixture (Gal.)		Total Number Of Fixtures		Total (Gal)
Shower:					
(3 GPM Head)	21.0	X	1	=	21.0
(5 GPM Head)	35.0	X		=	
(7 GPM Head)	49.0	X		=	
Bath (30 Gal. Tub)	21.0	X	1	=	21.0
Vanity	2.8	X	2	=	5.6
Clothes Washer	48.0	X	1	=	48.0
Dishwasher	15.0	X	1	=	15.0
Kitchen Sink or Utility Tub	10.0	X	1	=	10.0
Peak Hour Demand = Total Column (d)					= 120.6
Peak Hour Demand x 1.20 = Adjusted Peak Hour Demand					= 144.7
1) Boiler Heating Capacity Required for selected water heater					= <u>110,000</u>
BTU/hr					
2) Boiler Heating Capacity Required for Space Heating					= <u>92,000</u> BTU/hr
(Heat Loss x 1.15)					(80,000 x 1.15)
Select a boiler with a Heating Capacity greater than or equal to (1) or (2), whichever is greater.					
Note: This worksheet is based on the following assumptions:					
a) 10 minute shower use per shower head per hour					
b) All other fixtures are used once during the hour					

IMPORTANT

Do not attempt to use Method C to size a single-family residence.

Method C: Commercial Sizing Method Directions

- 1) Table 5 and 6 show demands for various fixtures found in commercial buildings in gallons per hour. To determine the hot water requirements of the building:
 - a) Using Worksheet 2, determine and record the total number of each type of fixture in the building under Column (2)
 - b) Use Tables 5 and 6 to find the number of gallons of 140°F water used per hour per fixture. Record this value for each fixture in Column (1).
 - c) Multiply each line in Column (1) by the number in Column (2). The result is the total amount of water used for each type of fixture type per hour. Record this in Column (3).
 - d) Total Column (3). The result is the total amount of water used by all fixtures per hour. This is the possible maximum demand.
 - e) The demand factor is intended to take into consideration the fact that not all fixtures will be in use at the same time. Use the appropriate demand factor from Table 5. Multiply the total demand calculated in step (d) by this factor. The result is the probable maximum demand.
 - f) If a commercial dishwasher or laundry is on the job, determine the maximum amount of 140°F water, which could be used in an hour. This will depend upon the number of machines, the amount of water used per machine and the way in which the equipment is to be used. Consult the machine manufacturer and the building owner for this information. Once the maximum hourly usage is known for this equipment, enter it in the spaces provided under Column (3).
 - g) Add the hourly usage for dishwashers and washing machines to the Probable Maximum Demand. This is the Adjusted Probable Maximum Demand. Select the water heater
- 2)
 - a) If a new boiler is to be installed with the water heater, go to Table 1 and select a water heater which has a 140°F first hour rating greater than or equal to the Adjusted Probable Maximum Demand calculated in Method C step 1 g.
Determine the boiler size required to satisfy the space-heating requirement alone. Note the gross output or Heating Capacity of this boiler. Compare the boiler's gross output
required for the water heater and the gross output required for the space heating (Gross output required for space heating = heating load x 1.15). Use the boiler sized to the larger amount.

- b) If the water heater is to be installed with an existing boiler, go to table 1 and select a water heater which has a 140°F first hour rating greater than or equal to the adjusted probable maximum demand calculated in 1g. Note the boiler's gross output required to achieve the selected water heater's first hour ratings. If it is more than the gross output of the existing boiler, the existing boiler is too small to provide the proper input to the water heater.
- 3) Several water heaters may be used together to provide a greater first hour rating than the largest available single Artesian, if needed. If this is done, keep the following in mind:
- * The first hour ratings of several Artesians may be added together to give a first hour rating for the total system.
 - * The gross boiler output required for each individual water heater must be totaled to provide the gross boiler output required for the system.
 - * Use water heaters of equal size. Do not mix tanks of different sizes on the same manifold.
 - * See the "Piping" and "Wiring" sections of this manual for proper installation of a manifold system.
- 4) Note: Use of a storage tank can increase the system's performance by providing a buffer for periods of high demand.
- 5) Keep in mind the following before settling on the choice made above:

Many building's peak demands result from the constant use of one type of fixture or machine for a relatively short period of time (showers in a gymnasium, for example). The procedure outlined above may not provide adequate hot water in these cases. The best way to size water heaters for this type of application, is to determine the total flow rate of all fixtures. Which are, or could be, in use at once and select a water heater from Table 1, which will provide hot water at this flow rate for the period of time required.

**Method C – Commercial Sizing Method
Worksheet 2
Sizing Sheet: Commercial Applications**

Description	(1)		(2)		(3)
	140°F Water Gal/hr-Fixture		Number of fixtures		Fixture Total Gal/hr
Basins, Private Lavatory		X		=	
Basins, Public Lavatory		X		=	
Bathtubs		X		=	
Showers		X		=	
Circular Wash Sinks		X		=	
Semi Circular Wash Sinks		X		=	
Foot Basins		X		=	
Laundry, Stationary Tubs		X		=	
Kitchen Sink		X		=	
Dishwasher in Apartment	15	X		=	
Clothes Washer in Apartment	48	X		=	
Commercial Kitchen Fixtures:					
Vegetable Sink	45	X		=	
Single Pot Sink	30	X		=	
Double Pot Sink	60	X		=	
Triple Pot Sink	90	X		=	
Prescrapper (Open Type)	180	X		=	
Preflush (Hand Operated)	45	X		=	
Preflush (Closed Type)	240	X		=	
Recirculating Preflush	40	X		=	
Bar Sink	30	X		=	
	Total Column (3) Possible			=	
Maximum Demand			Demand Factor	=	X
			Probable Maximum Demand	=	
			Hourly Dishwasher Requirement	=	+
			Hourly Laundry Requirement	=	+
			Adjusted Probable Maximum Demand	=	

Method C - Commercial Sizing Sample Calculation Example 2

This application is for a motel with 20 rooms. Each of these rooms has the following fixtures: (1) Vanity, (1) Shower and (1) Bath

In addition, 5 rooms have an additional vanity. Also, there is a utility sink used by the staff for cleaning and a laundry with two machines

Solution:

Use Table 5 and the fixture count to complete the example worksheet in figure 3 (on next page). Note that we treated the vanities as "Private Lavatory Basins" and the utility tub as a "Laundry Tub". From discussions with the washing machine manufacturer and the motel owner, we find that 100 Gal/hr of 140°F water is used in the Laundry. This usage is recorded on the "Laundry Line" at the bottom of Worksheet 2. The demand factor of 0.25 for a hotel is from Table 6. The Probable Maximum Demand is $0.25 \times 1978 = 494.5$ GaVhr. To this, we add the 100 GaVhr laundry usage for an Adjusted Probable maximum Demand of 594.5 Gal/hr. From table 1, Select the most cost-effective combination of equal size Artesians that will satisfy this requirement. In this case 2 model 340's, with 305 gph first hour rating at 140°F, are selected. Combined first hour rating is 610 gph (2 x 305). The total gross boiler output required is equal to the requirement for each model multiplied by the total number of water heaters. In this case $2 \times 220 = 440$ MBH gross boiler output is required. Likewise, their total boiler water flow through the water heater zone is equal to the requirement for each water heater times the total number of water heaters. In this case $(2 \times 6.7) = 13.4$ gal / min.

FIGURE 3.
Method C Example 2
Use of worksheet 2: Commercial Applications

Description	(1)	x	(2)	=	(3)
	140°F Water Gal/hr-Fixture		Number Fixtures		Fixture Total Gal/hr
Basins, Private Lavatory	2	x	25	=	50
Basins, Public Lavatory		x		=	
Bathtub	20	x	20	=	400
Showers	75	x	20	=	1500
Circular Wash Sinks		x		=	
Semi Circular Wash Sinks		x		=	
Foot Basins		x		=	
Laundry, Stationary Tubs	28	x	1	=	28
Kitchen Sink		x		=	
Dishwasher in Apartment	15	x		=	
Clothes Washer in Apartment	48	x		=	
Commercial Kitchen					
Fixtures:					
Vegetable Sink	45	x		=	
Single Pot Sink	30	x		=	
Double Pot Sink	60	x		=	
Triple Pot Sink	90	x		=	
Prescrapper (Open Type)	180	x		=	
Preflush (Hand Operated)	45	x		=	
Preflush (Closed Type)	240	x		=	
Recirculating Preflush	40	x		=	
Bar Sink	30	x		=	
Total Column (3) Possible Maximum Demand					= 1978
Demand Factor					= X 0.25
Probable Maximum Demand					= 494.5
Hourly Dishwasher Requirement					= +
Hourly Laundry Requirement					= + 100.0
Adjusted Probable Maximum Demand					= 594.5

TABLE 5: Hot Water Demand Per Fixture for Various Types of Buildings – (Gallons of Water Per Hour Per Fixture, Calculated at a Final Temperature of 140°F)

	Apt. House	Club	Gym.	Hosp.	Hotel	Indus. Plant	Office Bldg.	Private Res.	School	YMCA
Basin, private lavatory	2	2	2	2	2	2	2	2	2	2
Basin, public lavatory	4	6	8	6	8	12	6	–	15	8
Bathtub	20	20	30	20	20	–	–	20	–	30
dishwasher	15	20-150	–	50-150	50-200	20-100	–	15	20-100	20-100
Foot basin	3	3	12	3	3	12	–	3	3	12
Kitchen sink	10	20	–	20	30	20	20	10	20	20
Laundry, stationary tub	20	28	–	28	28	–	–	20	–	28
Pantry sink	5	10	–	10	10	–	10	5	10	10
Shower	30	150	225	75	75	225	30	30	225	225
Service sink	20	20	–	20	30	20	20	15	20	20
Hydrotherapeutic shower				400						
Hubbard bath				600						
Leg bath				100						
Arm bath				35						
Sitz bath				30						
Continuous-flow bath				165						
Circular wash sink				20	20	30	20		30	
Semicircular wash sink				10	10	15	10		15	
Demand Factor	0.30	0.30	0.40	0.25	0.25	0.40	0.30	0.30	0.40	0.40

Reprinted by permission of the American Society of Heating, Refrigerating and Air Conditioning Engineers, Atlanta, Georgia, from the 1995 ASHRAE Handbook Applications.

TABLE 6: General Purpose Hot Water (140°F) Requirements for Various Kitchens Used

Equipment	GPH
Vegetable	45
Single Pot Sink	30
Double Pot Sink	60
Triple Pot Sink	90
Prescrapper (Open Type)	180
Preflush (Hand Operated)	45
Preflush (Closed Type)	240
Recirculating Preflush	40
Bar Sink	30
a) Supply water pressure at equipment is assumed to be 20 psi	
b) Dishwasher operation at 100% of mechanical capacity	

Reprinted by permission of the American Society of Heating, Refrigerating and Air Conditioning Engineers, Atlanta, Georgia, from the 1995 ASHRAE Handbook Applications.

IV. BEFORE STARTING INSTALLATION

- 1) Make sure that the planned installation is in accordance with all local codes.
- 2) Be certain the domestic water supply to the tank has physical and chemical characteristics that fall within the limits shown in Table 7. Where questions exist as to the composition of the water on the job, a qualified water treatment expert should be consulted.

IMPORTANT

Water with characteristics outside the limits shown in Table 7 may severely shorten the life of the heat exchanger due to corrosion. Damage to the heat exchanger is not covered under warranty. Do not use the water heater if the water is excessively hard. Lime and other deposits will occur and reduce the unit's effectiveness.

- 3) Read and understand all installation requirements in this manual.
- 4) When adding a water heater to an existing system, the additional water content of the tank must be considered. Verify that the expansion tank sizing is correct.

IV Locating The Artesian

WARNING

Failure to properly support a water heater tank installation could result in property damage or personal injury.

- 1) Table 2 shows the weights of all water heaters filled with water. The location chosen for the water heater must be capable of supporting both the weight of the water heater(s) and the weight of the boiler(s).
- 2) Locate the water heater in an area where a leak in the tank, or the adjacent piping, or an open temperature and pressure relief valve will not damage the surrounding structure. If the area around the desired tank location is highly susceptible to water damage, install the water heater in a pan with a drain.
- 3) The water heater may be located some distance from the boiler provided the piping system is designed to provide the minimum boiler water flow called for in Table 1. Also, the further the water heater is from the boiler, the longer the response time of the boiler will be to a call for heat from the water heater zone. If long runs exist between the boiler and the water heater, it is advisable to insulate the piping.

Table 7: Water Chemistry Requirements

Water used in the water heater must have characteristics falling within the following limits:

<u>Characteristic</u>	<u>Min.</u>	<u>Max.</u>
pH	6.0	8.0
Dissolved Chlorine (PPM)	0.0	100.0
No measurable amounts of chlorine containing compounds, such as cuprous chloride, are permitted.		

V. Piping

IMPORTANT

All First Hour Ratings shown in this manual are based on the, minimum boiler water, flow rates shown in Table 1. Read this section for information on sizing piping and circulators for the water heater zone. **Zone Design**

In designing the water heater zone piping system, the following points should be considered: 1) Circulator or Zone Valve Zoning? - Circulator zones are usually a better choice. Zone valves have a relatively high pressure, drop with respect to flow rate required through the water heater tank (see Table 1).

If zone valves are selected, use a zone valve with a minimal delay in opening, such as a motorized type.

- a) Priority Zoning - Priority zoning is used to divert all boiler output to the water heater when its zone calls for heat regardless of any simultaneous calls for heat from space heating zones
- b) Priority zoning can be done using a 3-way zone valve, or by using a relay to de-energize the heating zones when the water heater calls for heat. (See the piping and wiring sections for more information on these zone systems).

Boiler Side Piping

Figures 4-9 show typical boiler side piping for several common situations. Regardless of which system is used, it is imperative that the minimum boiler water flow rates called for in Table 1 are developed through the tank. This requires properly sized piping and a properly sized pump. The systems shown in figures 4-9 are described below:

Standard Circulator Zone

This system is just like the circulator zone system on a straight heat job except that one of the zones goes to the water heater tank instead of radiation. As on any circulator zone system, appropriate controls should be installed in each zone to prevent unwanted circulation through zones, which are not calling for heat. Figure 4 illustrates typical circulator zone piping.

Zone Valve System

As with the circulator zone system, this system is just like a standard heating only zone valve system except that one of the zones is connected to the tank. The circulator must be large enough to move the boiler water through the tank at the minimum boiler water flow rate called for in Table 1, regardless of the flow rate required through the heating zones. Figure 5 illustrates a typical zone valve system.

3-Way Zone Valve System

This system offers a simple method of prioritizing the tank (Diverting all boiler output to the tank when the tank thermostat calls for heat). In this system, a 3-way zone valve is used which has a common port, a "normally open" port, and a "normally closed" port. The zone valve motor is wired to be energized by the water heater thermostat (see Part VII for wiring information). The common side of the zone valve is connected to the boiler. The heating system is connected to the normally open side of the zone valve, and the water heater tank is connected to the normally closed side of the zone valve. As long as the water heater is not calling for heat, the boiler water can flow from the heating system zone, through the normally open side of the 3-way valve, to the boiler. As soon as the water heater calls for heat, the zone valve is energized, and boiler water can only flow through the water heater zone. Figure 6 illustrates typical piping using a 3-way zone valve.

Radiant Panel Or Other "Low Temperature System"

The first hour ratings published in this manual are based on an aquastat setting of 180°F in the tank. If, for whatever reason, the boiler water temperature going to the heating system is designed to be much under 180°F, special piping is needed to provide water to both the tank (high temperature) and the system (low temperature) at the proper temperatures. Two ways of doing this are with a heat exchanger or a 4-way valve.

In either system, the water heater must be connected to the boiler before any means used to control the temperature of the water going to the system. The temperature of the water going through the water heater is thus limited only by the boiler high limit setting. The high limit setting on the boiler aquastat should be set 15-20°F higher than the tank aquastat on the Artesian.

Figure 7 illustrates the use of a heat exchanger to control the temperature of the water going to the "low temperature" system. This heat exchanger may be shell and tube, plate type, or a second Artesian. The low temperature system water is completely isolated from the water passing through the boiler and Artesian. For this reason, the low temperature system must be equipped with its own expansion tank, fill, and air removal apparatus. The temperature in this system may be controlled with an aquastat in the low temperature side.

Figure 8 illustrates the use of a 4-way valve to control maximum heating zone (low) temperature while allowing high temperature boiler water to enter the tank zone. The 4-way valve may be manually set to provide the maximum allowable temperature to the heating zone or it may be provided with a motor to control the valve in response to some parameter (outdoor temperature for example).

Artesian Manifold Piping (Boiler Side)

Multiple tank installations must be done in the "reverse return" manner illustrated on figure 9. The reason for this is to create the same pressure drop (and therefore the same flow) through each tank. The boiler manifold piping must be sized so that each tank has the flow rate called for in Table 1. For example, if two model 220's (90 MBH) are to be manifolded together, the circulator and zone piping common to both tanks must be capable of moving 5.4 GPM (2 x 2.7 GPM). The boiler must be capable of producing 180 MBH to supply the Water heater.

BOILER-SIDE PIPING USING CIRCULATOR ZONES

FIGURE 4

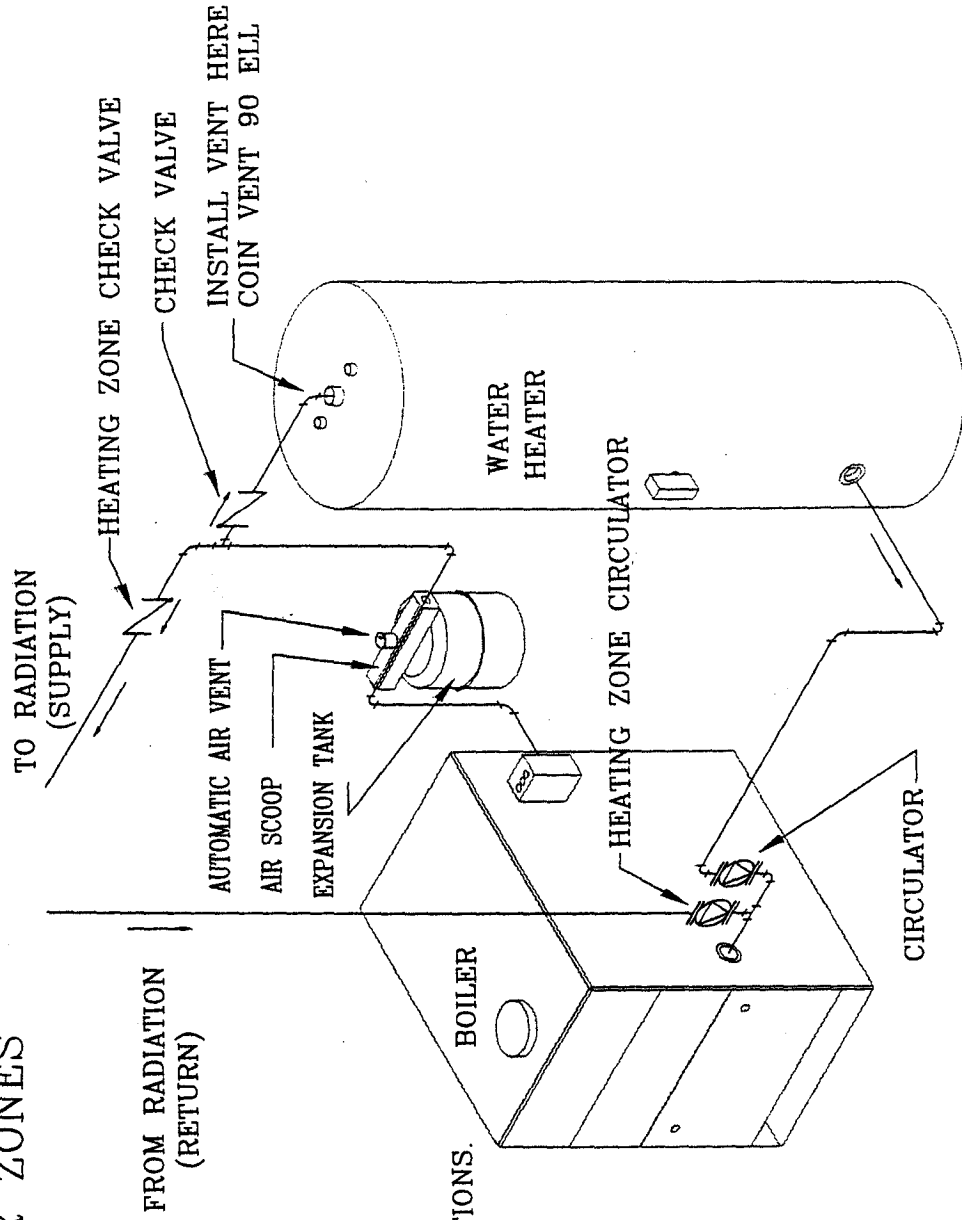

WARNING:
BOILER RELIEF VALVE
NOT SHOWN. INSTALL
IN ACCORDANCE WITH
MANUFACTURER'S INSTRUCTIONS.

BOILER—SIDE PIPING
 USING ZONE VALVES (2-WAY)

FIGURE 5

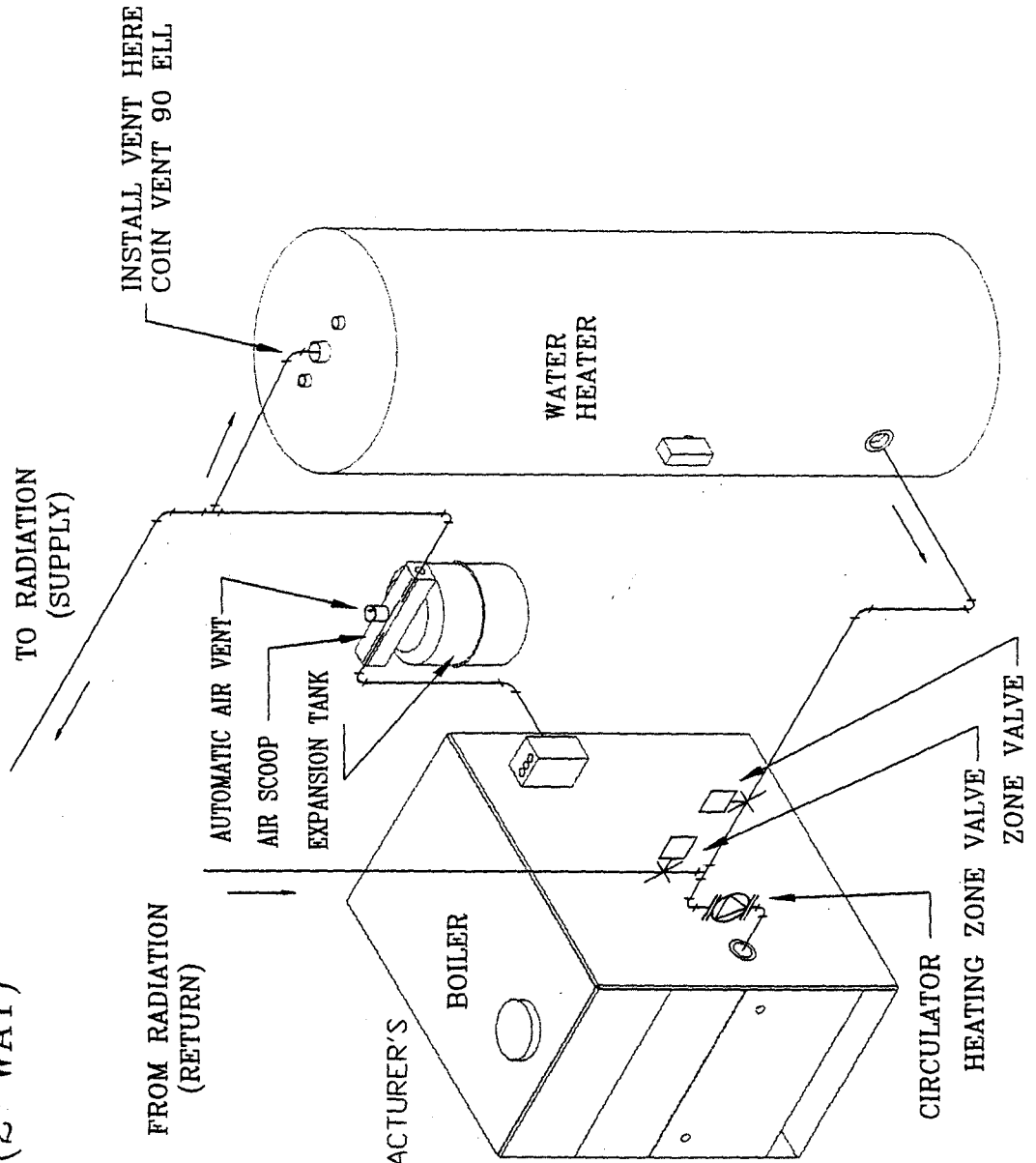

WARNING:
 BOILER RELIEF VALVE
 NOT SHOWN. INSTALL
 IN ACCORDANCE WITH MAUFACTURER'S
 INSTRUCTIONS.

**BOILER-SIDE PIPING
USING A THREE WAY ZONE VALVE**

FIGURE 6

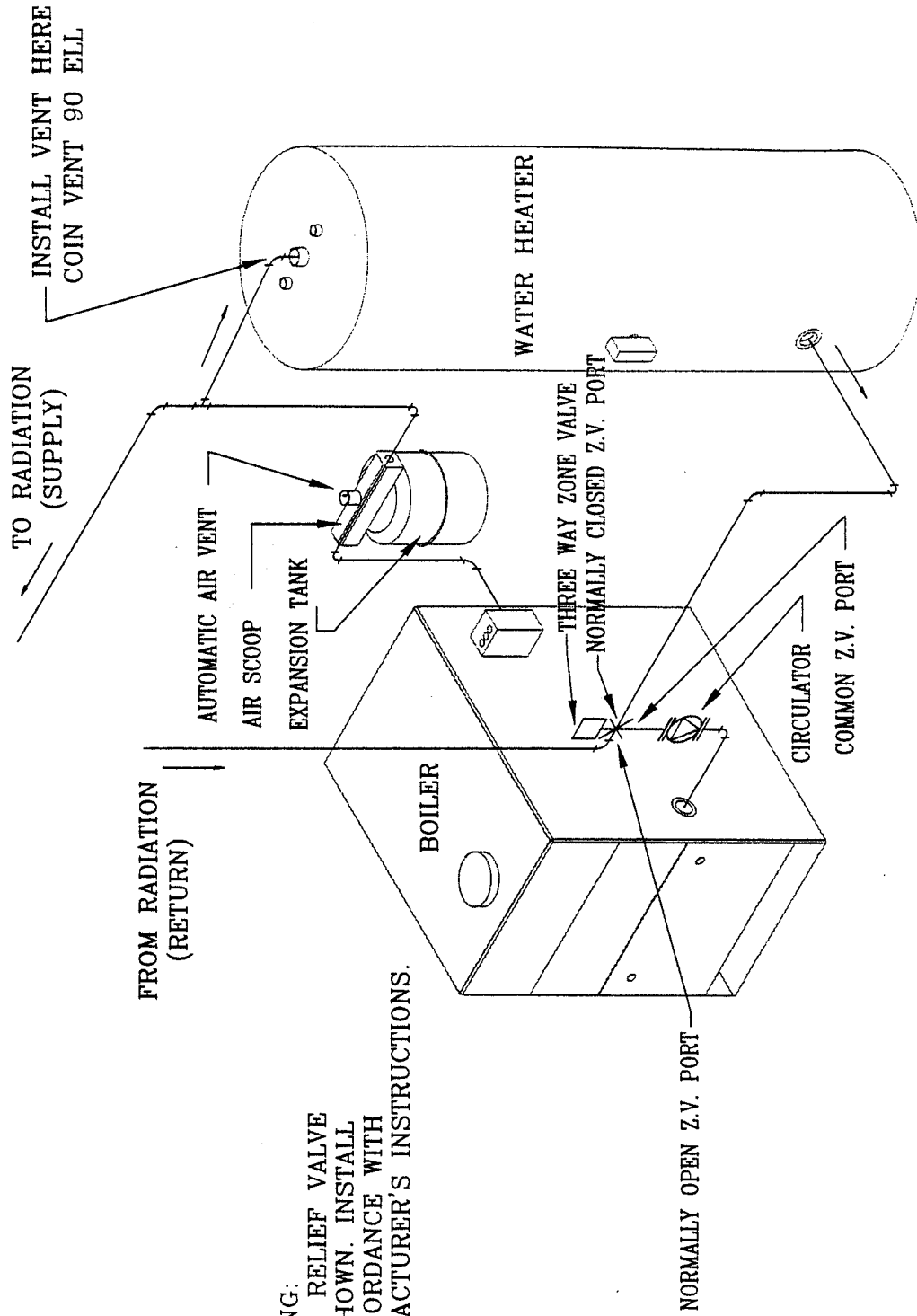

WARNING:
BOILER RELIEF VALVE
NOT SHOWN. INSTALL
IN ACCORDANCE WITH
MANUFACTURER'S INSTRUCTIONS.

BOILER-SIDE PIPING
 IN A RADIANT PANEL HEATING
 SYSTEM USING A HEAT EXCHANGER

FIGURE 7

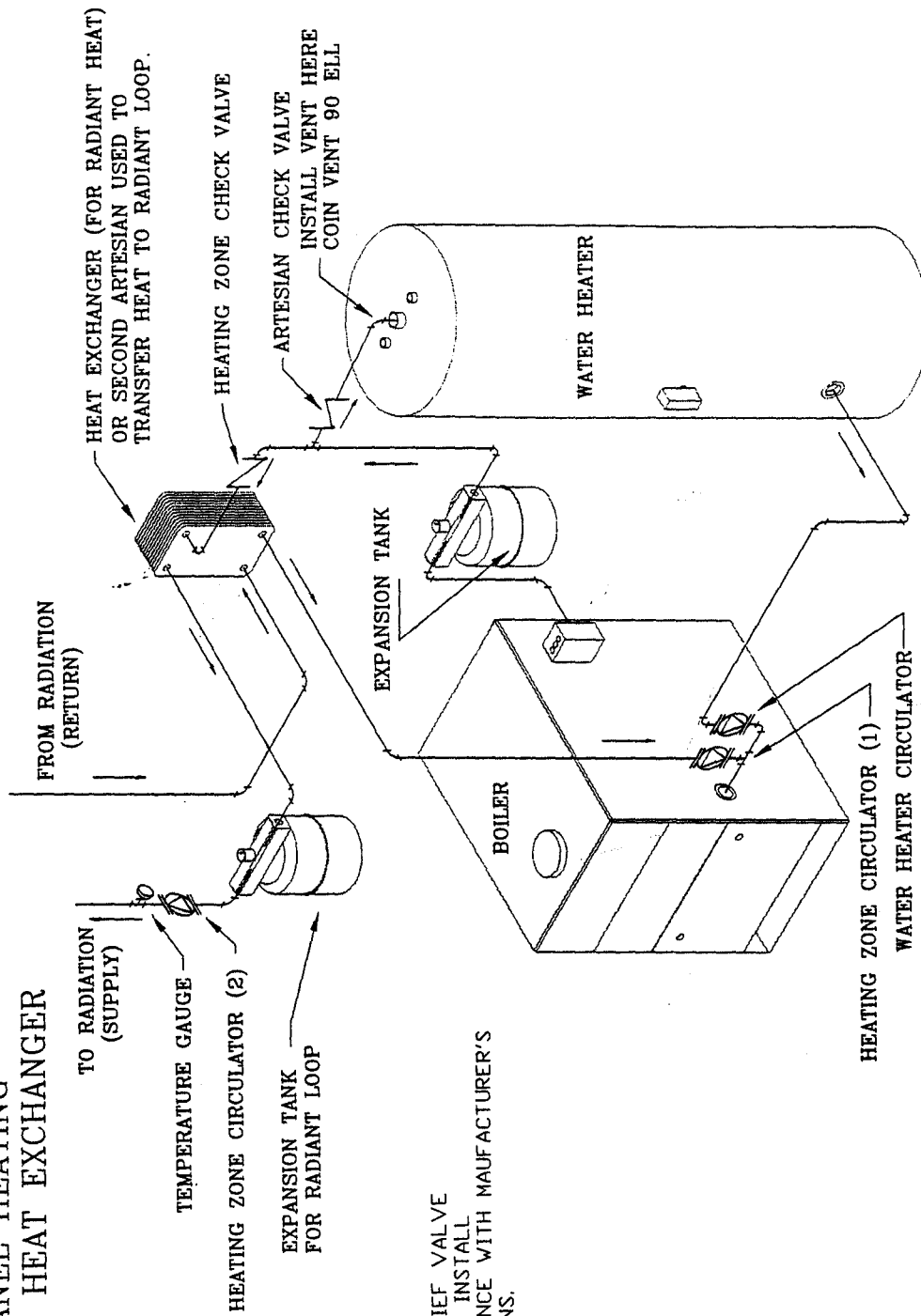

WARNING:
 BOILER RELIEF VALVE
 NOT SHOWN. INSTALL
 IN ACCORDANCE WITH MAUFACTURER'S
 INSTRUCTIONS.

BOILER-SIDE PIPING
 USING A (4 WAY VALVE)

FIGURE 8

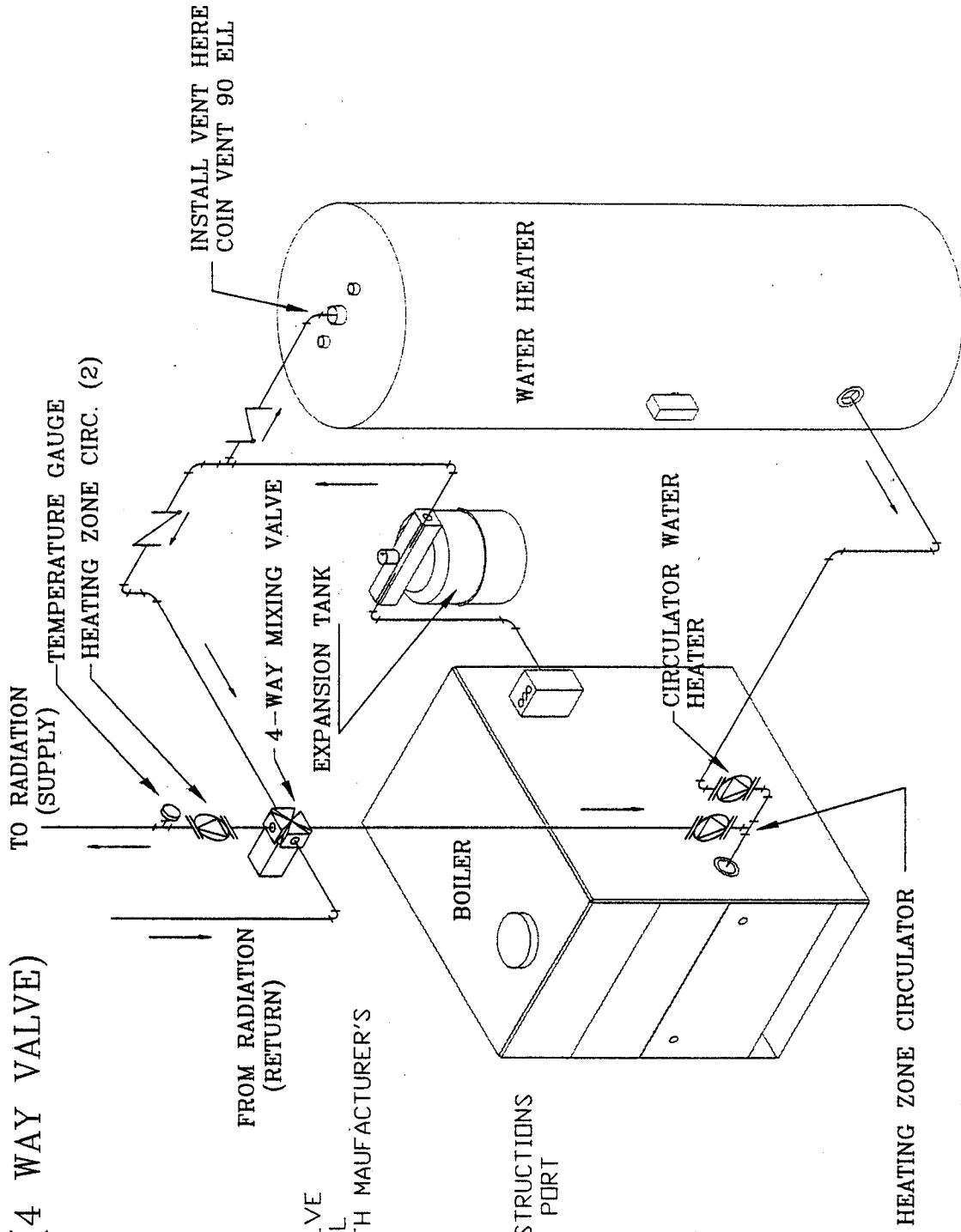

WARNING:
 BOILER RELIEF VALVE
 NOT SHOWN. INSTALL
 IN ACCORDANCE WITH MAUFACTURER'S
 INSTRUCTIONS.

SEE MIXING VALVE
 MANUFACTURER'S INSTRUCTIONS
 FOR PROPER VALVE PORT
 ORIENTATION.

BOILER-SIDE PIPING FOR MULTIPLE ARTESIANS

FIGURE 9

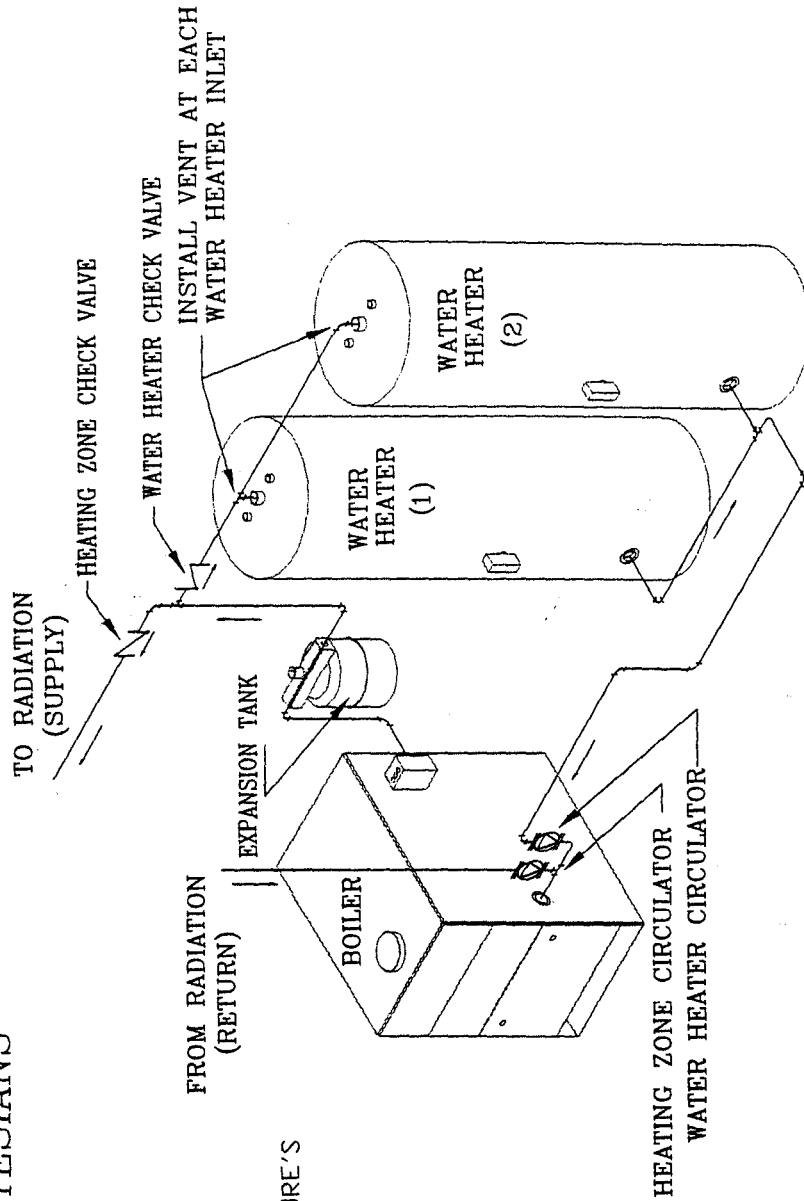

WARNING:
BOILER RELIEF VALVE
NOT SHOWN. INSTALL
IN ACCORDANCE WITH MAUFACTURE'S
INSTRUCTIONS.

REVERSE RETURN PIPING
(SHOWN) BALANCES PRESSURE DROP
THROUGH EACH WATER HEATER TANK.

2) Domestic Water Side Piping

Figure 10 shows typical domestic water piping for a water heater. All components except the aquastat are provided by the installer. The function of the components shown are as follows:

- a) Control (required) - This control is provided by Dunkirk and must be installed in the location indicated. It is imperative that the bulb of the control is "bottomed out" in the control well.
- b) Shut-off valves (recommended) - use to isolate the tank for servicing.
- c) Unions (optional) - Use to disconnect the water heater in the unlikely event that this is necessary.
- d) Temperature/Pressure Relief Valve (Optional) - Opens to relieve excess pressure or temperature, which has developed in the water heater's heat exchanger.
- e) Heat Trap (Optional) - The heat trap retards the migration of heat from the water heater upon the hot water supply pipe.

- f) The use of a flow restricter may be required to control flow rates when necessary.

Water heater Piping With A "Temperature Limiting Valve"

At first draw, the domestic water temperature will be equal to the control temperature setting on the tank.

The temperature of water going to the fixtures may be more carefully controlled with a thermostatic mixing valve. This device blends a controlled amount of cold water with the hot water leaving the water heater so that water at a more constant temperature exits the mixing valve. Typical thermostatic mixing valve piping is illustrated on figure12.

Warning

- Feel water before bathing or showering
- If anti-scald or anti-chill protection is required, use devices specifically designed for such service. Install these devices in accordance with their manufacturer's instruction.
- It is strongly recommended that a thermostatic mixing valve be used on all residential installations.

Domestic Water Piping for Distant Fixtures

in some cases, the furthest fixture may be quite distant from the water heater. In such an installation, there will be a slight delay before hot water reaches these distant fixtures. Even if all the fixtures are relatively close to the water heater, the building owner may want hot water at all fixtures as soon as they are opened. Figure 12 illustrates a solution to this problem. In it, a pipe is run from the furthest fixture on each branch back to the return of the water heater. A small bronze circulator is mounted in this line and is wired to run continuously. A check valve in this line permits flow towards the water heater inlet only.

When no fixtures are drawing water, the bronze circulator moves hot water from the water heater to the end of the branch just below the last fixture, then back to the inlet of the water heater via the return pipe. When a fixture is opened, hot water is already out in the branch very close to the fixture and hot water immediately appears. The check valve prevents cold water in the water heater's inlet pipe from passing around the tank and heading directly to the fixture. Because hot water is always circulated in the hot water branch, the entire branch should be insulated to prevent excessive heat loss.

Manifold Domestic Water Piping

Figure 13 illustrates the recommended method of piping the domestic waterside of several tanks together. All water heaters are piped in a "reverse-return" manner just like the boiler piping. This balances the pressure drop through each coil, resulting in an even flow rate through each coil. Each coil must have its own temperature and pressure valve. It is recommended that each tank be equipped with its own isolation valves, unions and drains so that one tank may be removed from the system.

FIGURE 10

BASIC DOMESTIC WATER PIPING

NOTE:

A THERMAL EXPANSION TANK MAY BE REQUIRED IN THE DOMESTIC WATER PIPING SYSTEM TO OFFSET THE EXPANSION OF STORED DOMESTIC WATER AS THE TANK TEMPERATURE INCREASES. (THIS IS REQUIRED ONLY IN SYSTEMS WHERE THERE IS NO RETURN VALVE, OR WHERE A BACK FLOW PREVENTER, CHECK VALVE OR A WATER METER ARE INSTALLED ALLOWING PRESSURE TO BUILD UP AS THE WATER IS HEATED). SEE DIAGRAM BELOW.

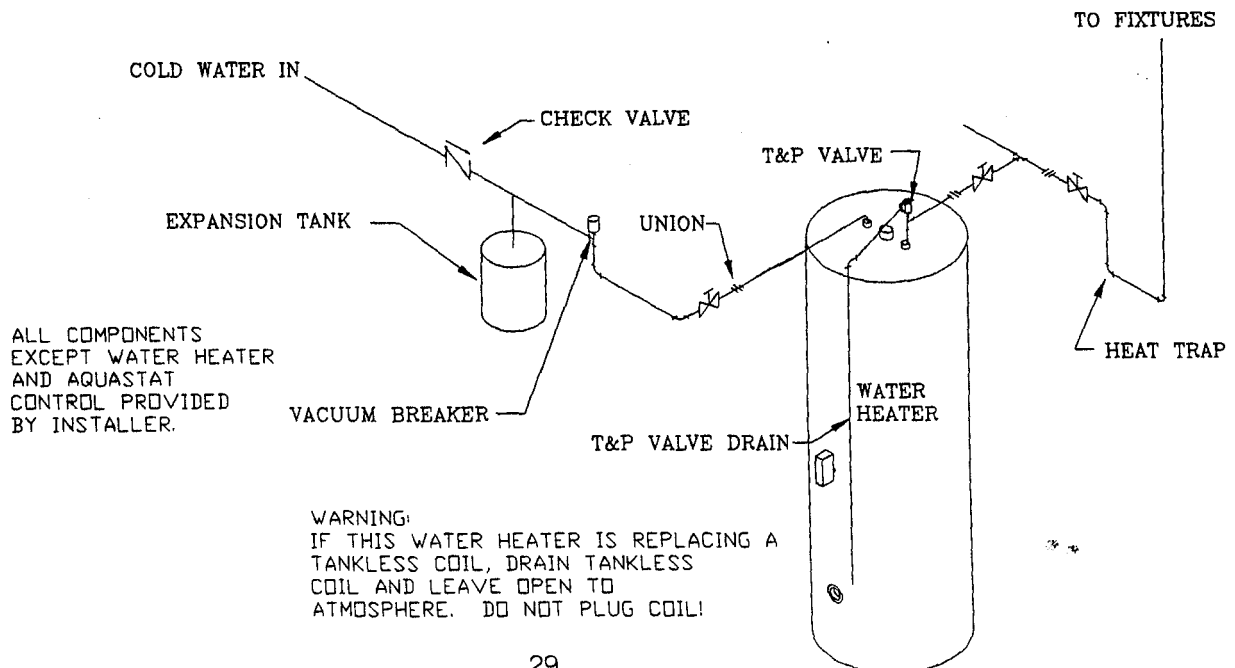

DOMESTIC HOT WATER PIPING USING A MIXING VALVE

FIGURE 11

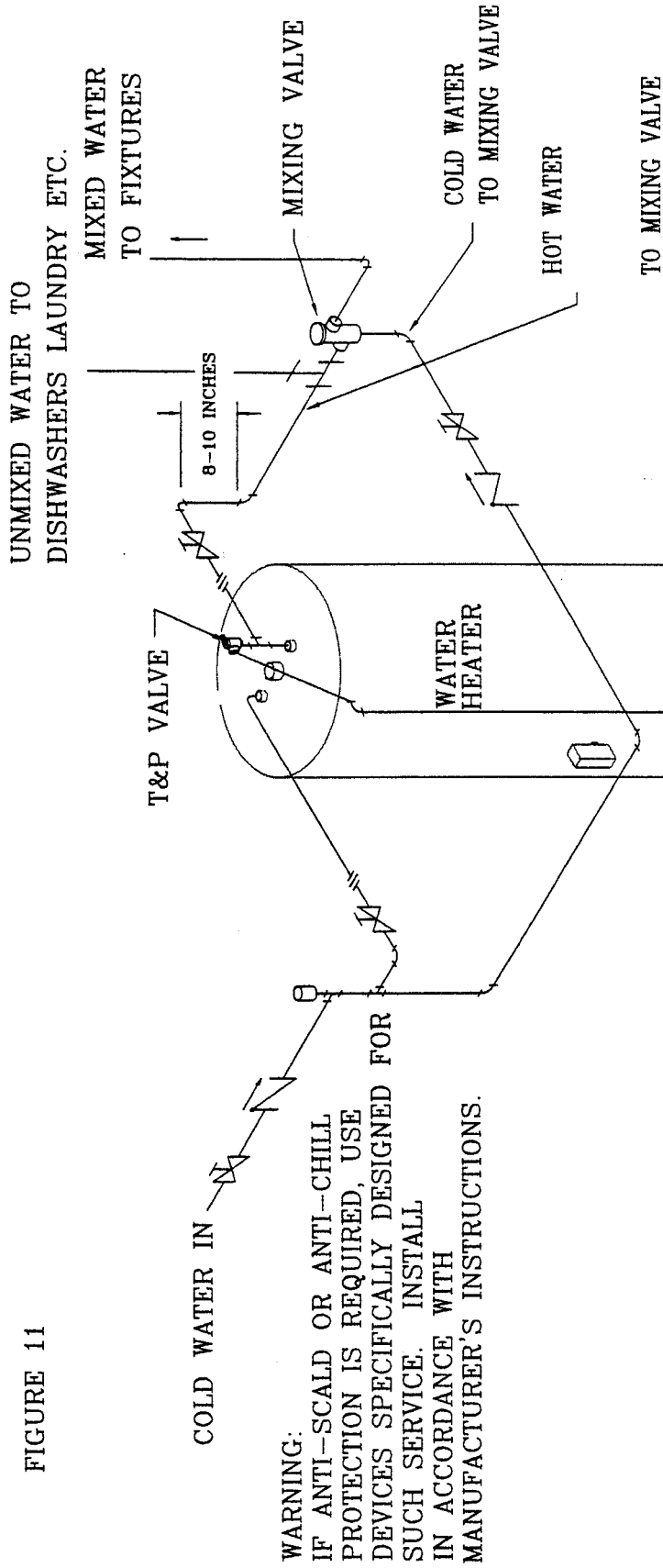

WARNING:
IF ANTI-SCALD OR ANTI-CHILL PROTECTION IS REQUIRED, USE DEVICES SPECIFICALLY DESIGNED FOR SUCH SERVICE. INSTALL IN ACCORDANCE WITH MANUFACTURER'S INSTRUCTIONS.

DOMESTIC WATER PIPING FOR DISTANT
FIXTURES USING A RECIRCULATING LINE

FIGURE 12

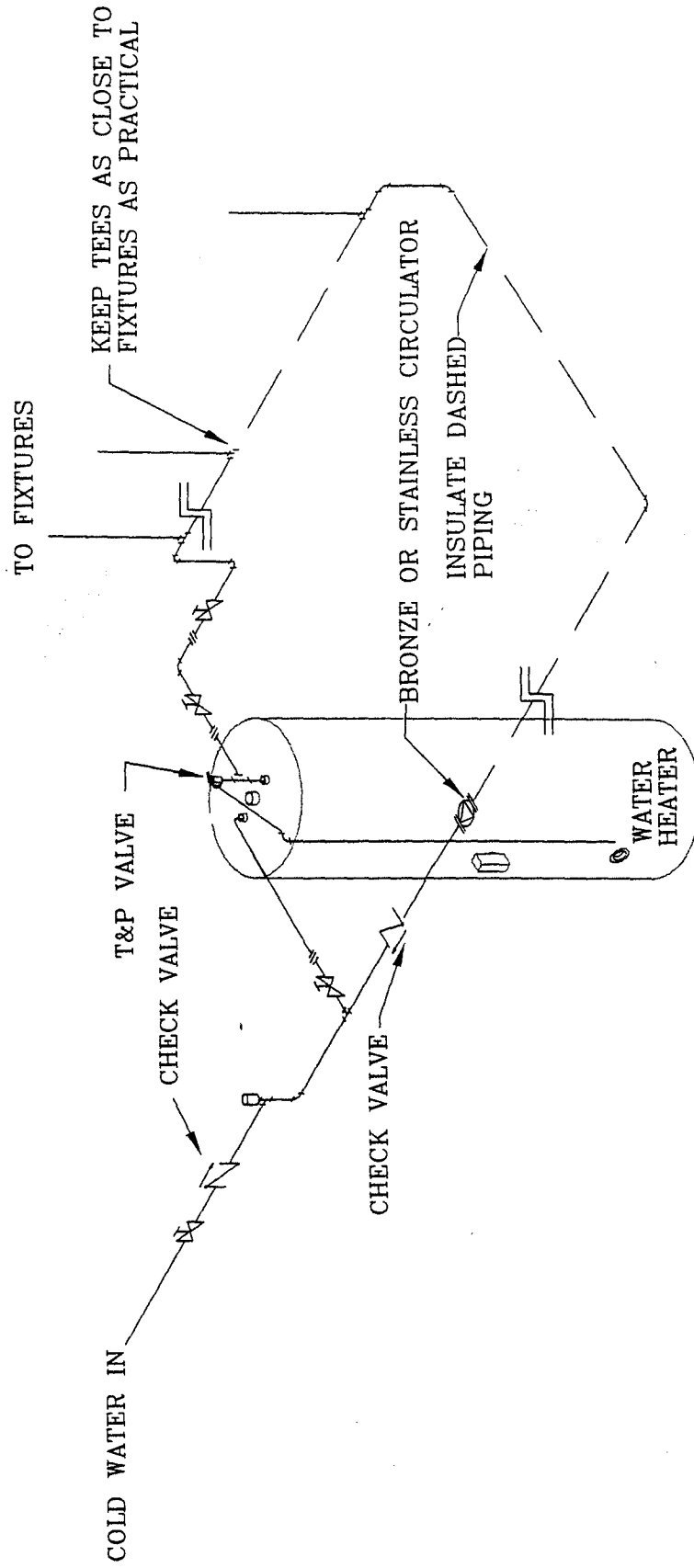

DOMESTIC HOT WATER PIPING
USING MULTIPLE WATER HEATERS

FIGURE 13

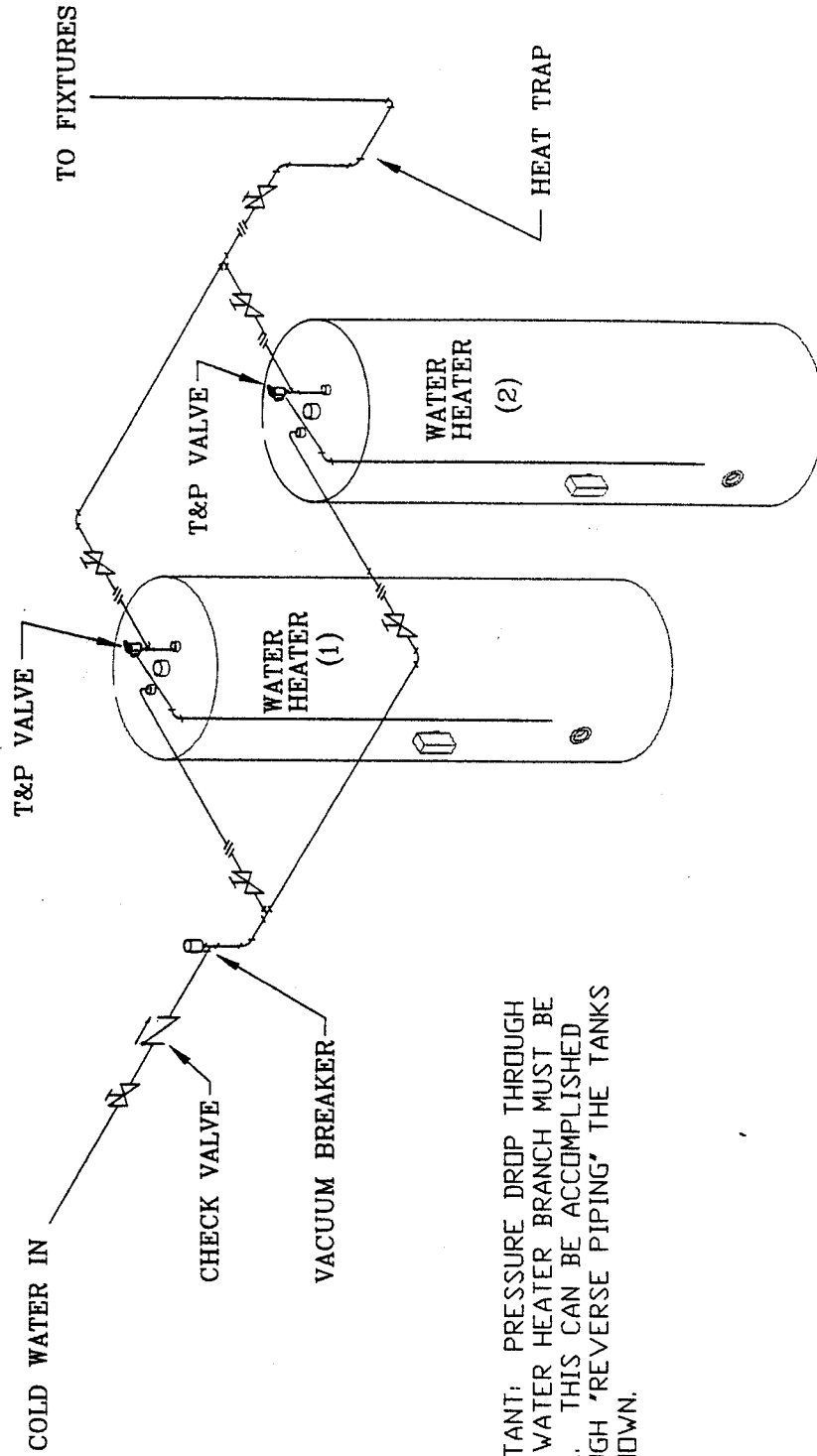

IMPORTANT: PRESSURE DROP THROUGH EACH WATER HEATER BRANCH MUST BE EQUAL. THIS CAN BE ACCOMPLISHED THROUGH "REVERSE PIPING" THE TANKS AS SHOWN.

VII. Wiring

The following applies to all wiring:

- 1) **Wiring must be done in accordance with all codes.** In the absence of any codes, the system must be wired in accordance with the National Electric Code (ANSI/NFPA 70-latest revision).
- 2) The entire system (boiler controls, water heater and heating zone controls) must be on its own circuit. The current rating of this circuit will depend on the total number and size for loads in the system. However, it should in no case be less than 15 AMPS.
- 3) The water heater is equipped with a Honeywell L4080B-1378 series aquastat. This aquastat has an operating range of 100°F to 200°F with a 15° differential. The switch contacts will open at the aquastat set point and close at the set point minus the differential.

Circulator Zone Wiring (Non Priority)

Figure 14 is a connection diagram for a non-priority circulator zone system using Honeywell R845A's. The R845A is equipped with two sets of contacts (3,4 and 5,6) which become made when the T and T terminals are made. Terminals 1 and 2 on the R845A are supplied with 110 VAC to power its internal transformer. In this application, one R845A is provided for each zone, including that of the water heater. If the boiler has a factory equipped circulator, this is disconnected from terminals C1 and C2 on the boiler control.

When any thermostat (including the thermostat on the water heater) calls for heat, the relay in the R845A for that zone becomes energized. Terminals 3 and 4 become made, energizing the circulator. Terminals 5 and 6 are also made which start the boiler.

Circulator Zone Wiring (Priority)

Figure 16 is a connections diagram for priority circulator zoning. This system is similar to non-priority circulator zoning except that a Honeywell R8285B relay is used in place of the R845A on the water heater zone. This relay is equipped with its own 24 volt transformer and D.P. D.T contacts. The water heater control is connected to terminals R and G so that when the water heater control calls for heat, the relay is energized.

One set of contacts on the R8285B is used to switch line voltage. On this set of contacts, the common is connected to an unswitched "hot". The normally closed contact is connected to terminal #1 on each of the space heating zone's R845A's. The normally open contact is connected to the water heater zone circulator. The normally closed contact on the other set of R8285B contacts is not used. The common and normally open contacts are connected in parallel with terminals #5 and #6 on the space heating zone R845A's.

As long as the water heater zone does not call for heat, the R845A's for the heating zones have 110 VAC across their 1 and 2 terminals and the heating zones will function as described in the non-priority circulator zone section. As soon as the water heater calls for heat, however, the normally closed terminals in the R8285B open, de-energizing the heating zones and energizing the water heater circulator. The other set of contacts in the R8285B (connected across the boiler thermostat connections) make which brings on the boiler.

Zone Valves (Non-Priority)

Figure 18 shows a connection diagram for a zone system using Honeywell V8043F motorized zone valves. The motor on these valves is connected between TH and TR. TH/TR is provided for the electrician's convenience as a binding post and is connected to nothing inside the valve. The end switch terminals are connected to a set of switch contacts inside the valve, which make when the valve is open.

A call for heat from any thermostat or the water heater's aquastat results in the application of 24 volts across the motor in that zone's zone valve. This drives open the zone valve. When the valve has opened, the end switch in that zone valve makes and brings on the boiler.

Zone Valves (2 Way Priority)

Figure 17 shows a connections diagram for a priority zone system using Honeywell V8043F motorized valves. An R8285B relay is used which is equipped with its own transformer and a set of D. P. D.T contacts.

The water heater control is connected to terminals R and G on the R8285B so when the water heater control calls for heat, the relay coil is energized. One side of the transformer is connected to the common contact. The normally closed contact is connected to all space heating thermostats. The normally open contact is connected directly to the water heater zone valve motor.

As long as the water heater is not calling for heat, power is supplied to all space heating thermostats and a call from any space heating thermostat will energize that zone's zone valve and bring on the boiler. As soon as the water heater calls for heat, however, the normally closed contacts open, which supply all power to the space heating thermostats, de-energizing the heating zones and closing any open space heating zone valves. At the same time, the normally open contacts in the R8285B become made which energizes the water heater zone valve. The water heater zone valve opens and its ends switch brings on the boiler.

If three (3) or more zones (including the water heater zone) are present use an external 24v transformer.

Zone Valves (3 Way Priority)

Figure 15 shows a connection diagram for a Honeywell 3-way zone valve. This valve is equipped with 4 connections, 2 of which are for a 24 volt motor and 2 of which are end switch connections which make when the valve is open.

As long as the water heater is not calling for heat, a call from the space heating thermostat will start the boiler and water will circulate to the space heating zone through the normally open port of the zone valve (see the piping section for more information on this). If the water heater thermostat calls for heat, however, the zone valve motor is energized and boiler water is redirected through the water heater's tank regardless of the status of the space heating thermostat.

Manifold Wiring

Wiring for manifolded water heaters is identical to the wiring for a single water heater except for the presence of more than one tank aquastat.

If unions and isolation valves -are present so that any tank could be pulled from the manifold without shutting down the entire tank zone, install all the aquastats provided and wire them in parallel. In this way, any tank can be completely removed from the manifold while allowing operation of the other water heaters.

Wiring notes:

- 1) These are some typical examples not the only possibilities.
- 2) Many types and brands of priority and non priority zone valve and zone pump controllers are available which may be used. Follow control manufacturers instructions.

CIRCULATOR ZONE WIRING (NON-PRIORITY) USING HONEYWELL R845'S

FIGURE 14

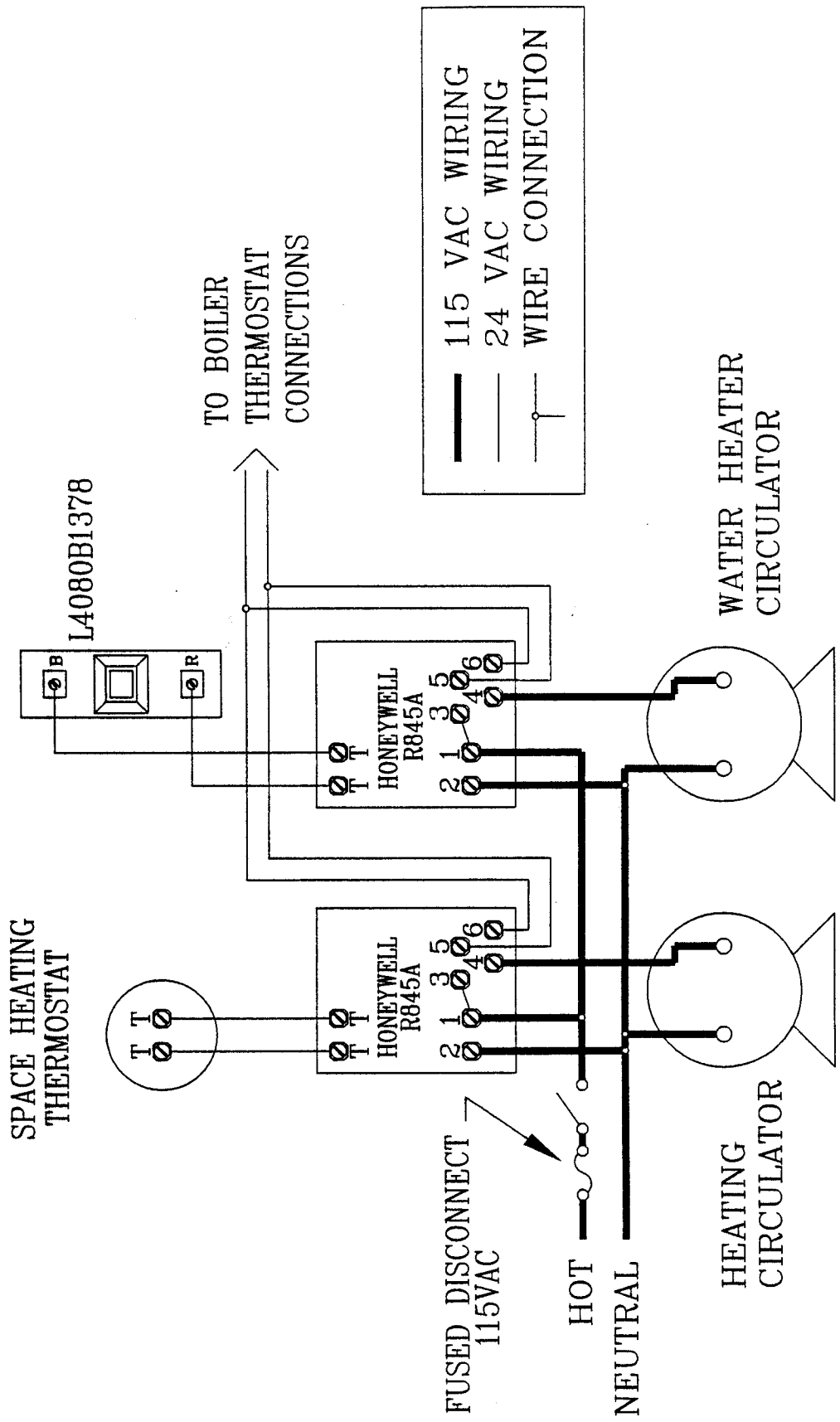

ZONE VALVE WIRING (3-WAY VALVE, PRIORITY)

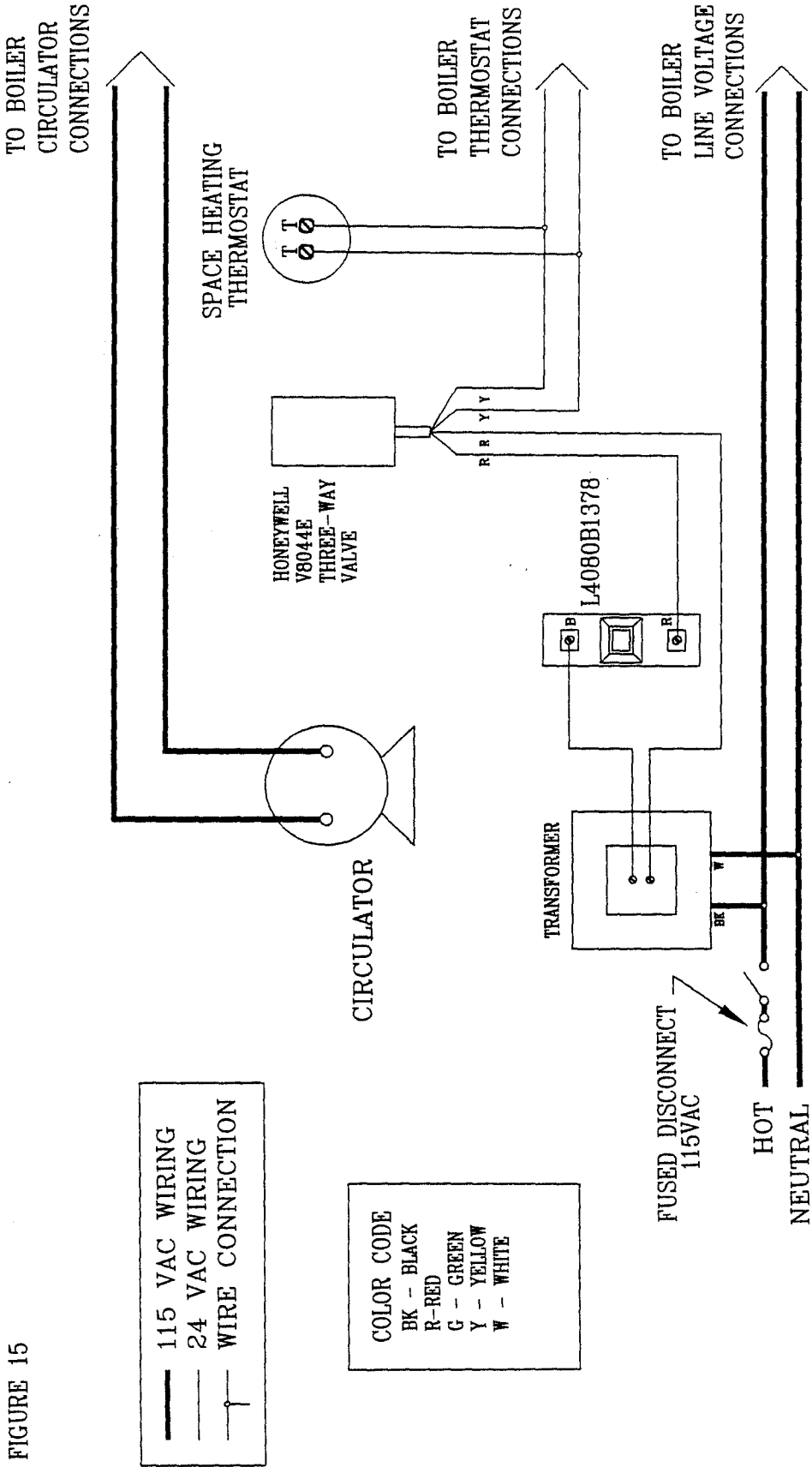

CIRCULATOR ZONING (PRIORITY)

FIGURE 16

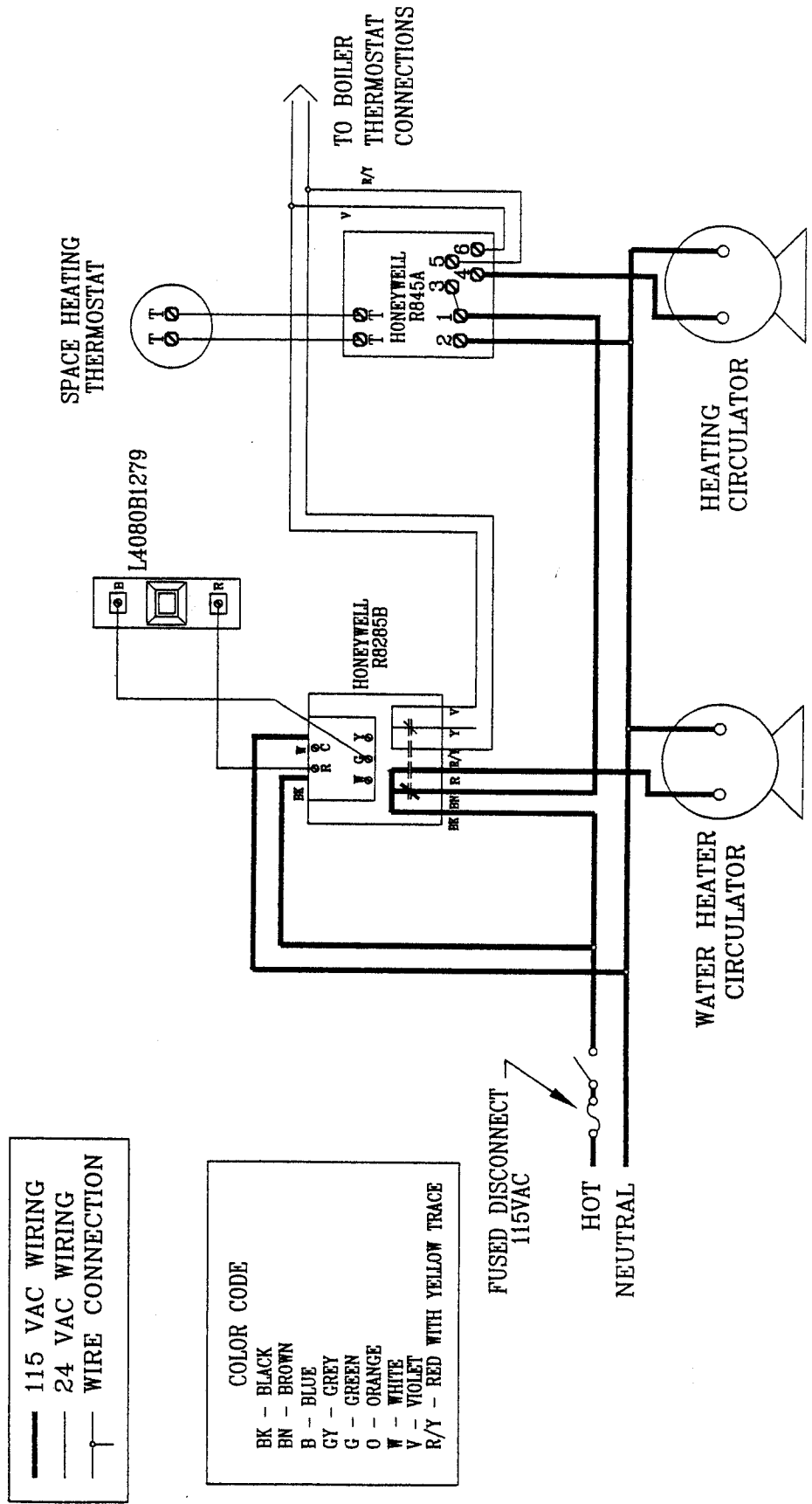

	115 VAC WIRING
	24 VAC WIRING
	WIRE CONNECTION

COLOR CODE	
BK	- BLACK
BN	- BROWN
B	- BLUE
GY	- GREY
G	- GREEN
O	- ORANGE
W	- WHITE
V	- VIOLET
R/Y	- RED WITH YELLOW TRACE

ZONE VALVE WIRING (2-WAY VALVES, NON-PRIORITY)

FIGURE 18

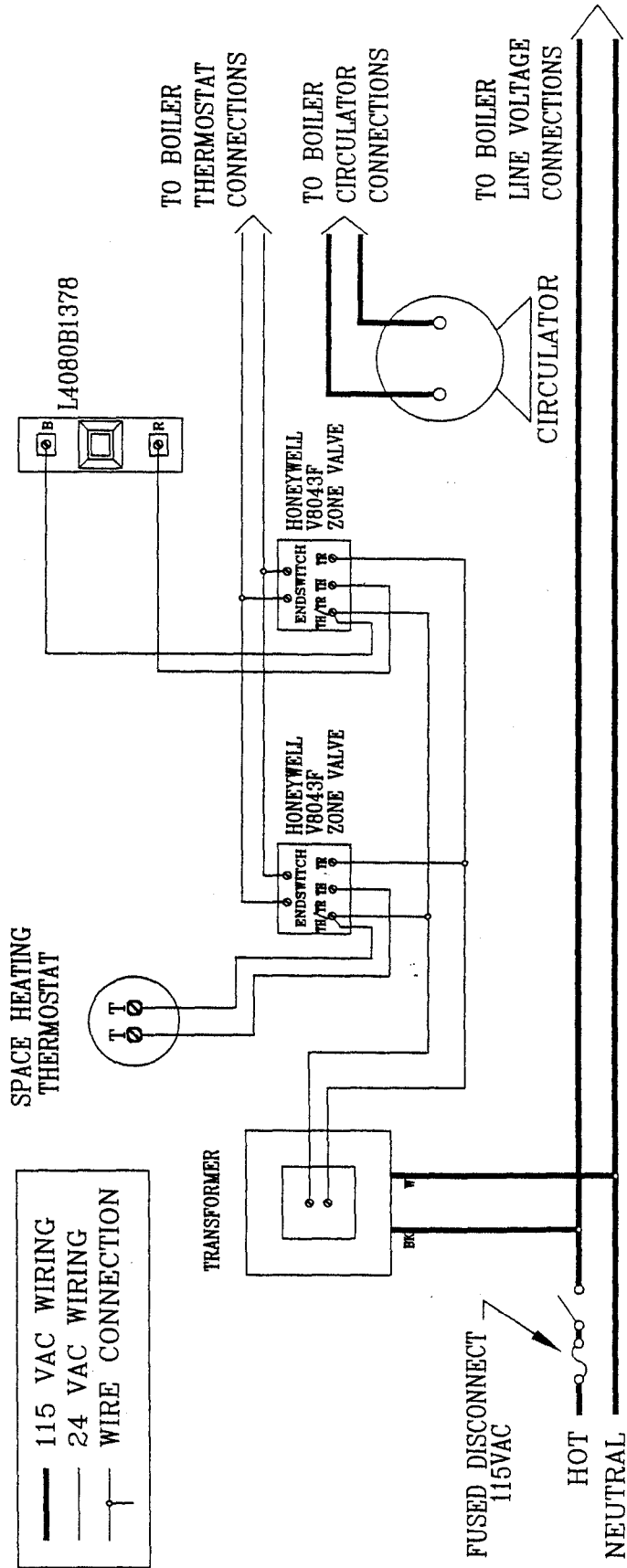

VIII Start up and Check out

IMPORTANT

IDENTIFY ANY LEAKS, BY TESTING, BEFORE PROCEEDING FURTHER. **WARNING**

NEVER ATTEMPT TO FILL A HOT BOILER.

- 1) Be sure to purge all air from water heater and ancillary piping.
- 2) Be sure that all electrical wiring has been done according to the local codes.
- 3) Verify that all zone valves or circulators operate properly when their thermostats call for heat. Allow the zones to operate long enough to purge any remaining air.
- 4) Set the water heater tank aquastat to the desired temperature setting. Then set the boiler aquastat to 20°F higher than water heater aquastat. To achieve the ratings listed in this manual it is recommended that the aquastat should be set at 180°F, and the boiler aquastat should be set at 220°F.
- 5) Be sure that the water heater aquastat cycles the boiler properly, and that the system reaches and maintains the desired temperature.

Appendix A: Whirlpool Sizing/ Hot Tub **IMPORTANT**

This procedure is not intended to size Whirlpool tubs in commercial applications. Commercial Whirlpool tubs present special sizing problems because of the large rate (as much as 20 GPM) at which they fill. The following procedure is predicated upon a water heater supply temperature of 140°F.

Before using this procedure, it is important to determine whether the tub in question is a Whirlpool tub or a "hot tub". A hot tub has its own water heating source and is not refilled each time it is used. In this way it is like a miniature swimming pool. Do not attempt to use this procedure for a hot tub. A Whirlpool tub is refilled each time it is used and in this way resembles an over-grown bathtub.

- 1) If not already done, use one of the procedures in Part III to size a water heater boiler combination for all fixtures except the Whirlpool tub.
- 2) The water heaters are ideally suited for most Whirlpool tub applications. This is due to minimal amount of recovery time required by the water heater.

To size the water heater for a Whirlpool tub application, consult the tub manufacturers literature for the flow rate. Match the flow rate to an acceptable flow rate found in Table 1. Take the first hour ratings at 140°F from Table 1 and divide by 60 to obtain gpm flow rate.