

CONVERSION INSTRUCTIONS

LP TO NATURAL GAS (SEA LEVEL TO 2000 FEET)

Cast Iron Gas Fired Water Boilers

15B, UH15B, BWB, GMGWB

For Forced Hot Water

⚠ WARNING

This conversion kit shall be installed by a qualified service agency in accordance with the manufacturer's instructions and all applicable codes and requirements of the authority having jurisdiction. If the information in these instructions is not followed exactly, a fire, an explosion or production of carbon monoxide may result causing property damage, personal injury or loss of life. The qualified service agency is responsible for the proper installation of this kit. The installation is not proper and complete until the operation of the converted appliance is checked as specified in the manufacturer's instructions supplied with the kit.

Tools Required

Flat Head Screwdriver, 1/4" Nut Driver, 7/16" Open Ended Wrench, 3/16" Allen Wrench, 18" Manometer (or dial manometer)

Installation

1. Turn off gas supply to the boiler.

⚠ WARNING

Electrical shock hazard. Turn OFF electrical power supply at service panel before making electrical connections. Failure to do so could result in death or serious injury.

2. Turn off all electrical to boiler.
3. Remove front panel.
4. Remove burner access door.
5. Remove main gas burner tubes. See Figure 1.
6. Remove main burner orifices. See Figure 1.
7. Install supplied natural gas main burner orifices. See table for orifice size and quantities.
8. Use 7/16" wrench, disconnect pilot tube from pilot. See Figure 2.
9. Remove pilot orifice. See Figure 2.
10. Install natural gas pilot orifice. See Figure 2.
11. Apply liquid sealing compound to threads of pilot assembly fitting.
12. Attach pilot tube to pilot and securely tighten. See Figure 2.
13. Replace LP main burner tubes, if present, with natural gas tubes. See Figure 3.

KIT CONTENTS	
ITEM	QTY.
Installation Instructions	1
Conversion Plate/Label	1
Pilot Orifice - Spark	1
Pilot Orifice - 24 Volt	1
Liquid Sealing Compound	1
Spring Kit	1

PILOT ORIFICES	
MFG.	PART NUMBER
Honeywell	390686-4*

*Use 390686-37 for Boilers Manufactured before July 2008 with Q381 Pilot.

Figure 1

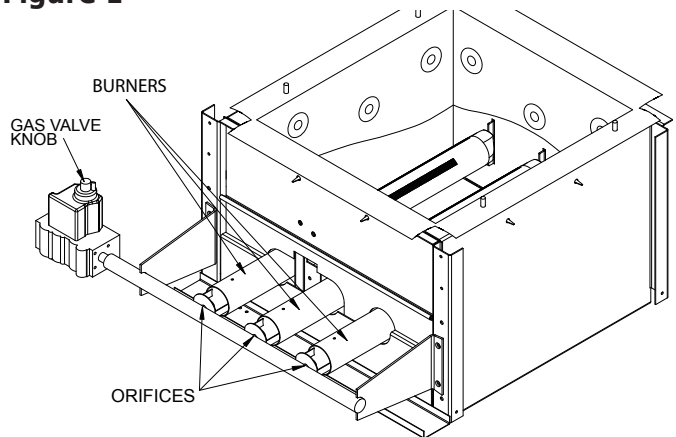
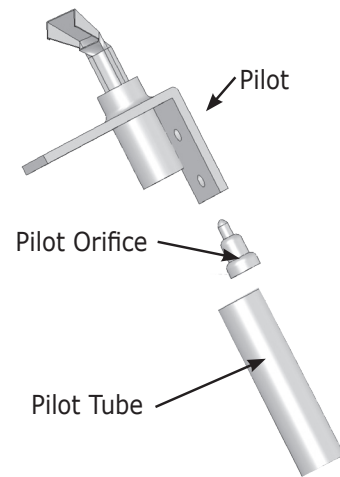



Figure 2



LP TO NATURAL GAS CONVERSION INSTRUCTIONS

14. Remove the cover screw from gas valve pressure regulator. See Figure 4.
15. Remove adjustment screw by turning counterclockwise . See Figure 5.
16. Remove red LP gas spring. See Figure 5.

NOTICE

Parts for steps 17, 18, 26, and 27 are located in the Honeywell natural gas conversion kit HW#394588 (#VG00802) for VR8200, VR8204, VR8300 or VR8304 gas valve or conversion kit HW#391936 (#VG00701) for VR8440 gas valve.

17. Insert stainless steel natural gas spring. See Figure 5.
18. Install adjustment screw. Verify screw top is flush with regulator top.
19. Turn pressure regulator adjustment screw clockwise  eight (8) complete turns. This is starting point for manifold pressure.
20. Install manometer to pressure tap on outlet side of gas valve. See Figure 4.
21. Turn ON electric and gas supply.

NOTICE

Verify gas inlet pressure is between minimum of 5" w.c. maximum of 14" w.c.

22. Check for gas leaks around all gas connections using commercially available soap solution specifically made for leak detection.

DANGER

Fire Hazard. Do not use matches, candles, open flames, or other methods providing ignition source. Failure to comply will result in death or serious injury.

23. With boiler operating adjust manifold pressure to 3½" water column by turning pressure regulator adjustment screw.
24. Turn OFF electric and gas supply.
25. Remove manometer. Replace pressure tap cover screw securely.
26. Install silver natural gas regulator adjustment cover screw with o-ring. See Figure 5.
27. Mount conversion label on gas valve.
28. Turn electric and gas supply ON.
29. Cycle boiler to ensure proper operation and lighting.
30. Replace front panel.
31. Fill out and affix conversion plate adjacent to rating plate. Complete this step to provide proper identification for customer service or technical support issues.

CAUTION

WHAT TO DO IF YOU SMELL GAS

- Do not try to light any appliance.
- Do not touch any electrical switch; do not use any phone in your building.
- Immediately call your gas supplier from a neighbor's phone. Follow gas supplier's instructions.
- If you cannot reach your gas supplier, call the fire department.

MAIN BURNER ORIFICES

INPUT (Btuh)	ORIFICE (mm)	QTY.
45,000	3.1	1
70,000	2.8	2
96,000	3.2	2
120,000	2.9	3
145,000	3.2	3
170,000	2.9	4
175,000	3.0	4
195,000	3.2	4
245,000	3.2	5
295,000	3.2	6

Figure 3 - Burners

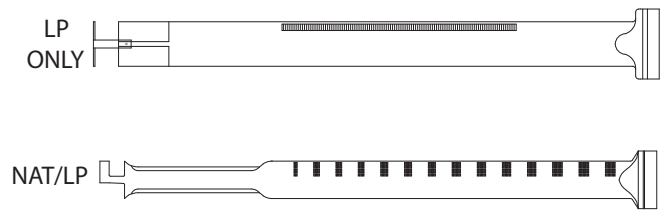
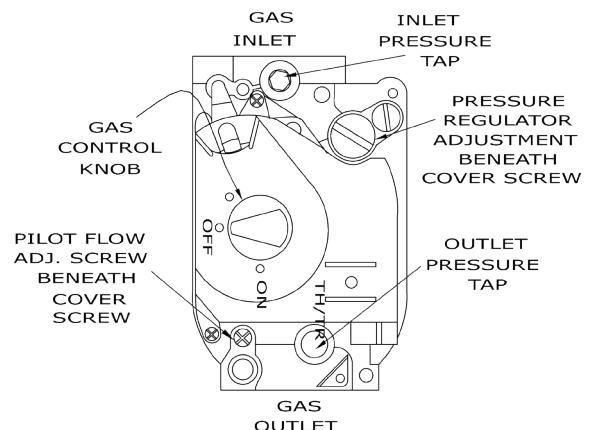

Figure 4 - Gas Valve



SEQUENCE OF OPERATION

Figure 5 - Gas Valve

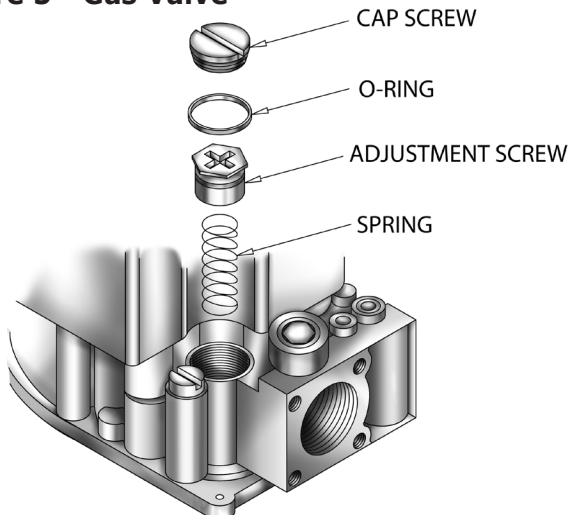

Figure 6 - Burners, Gas Valve, & Manifold

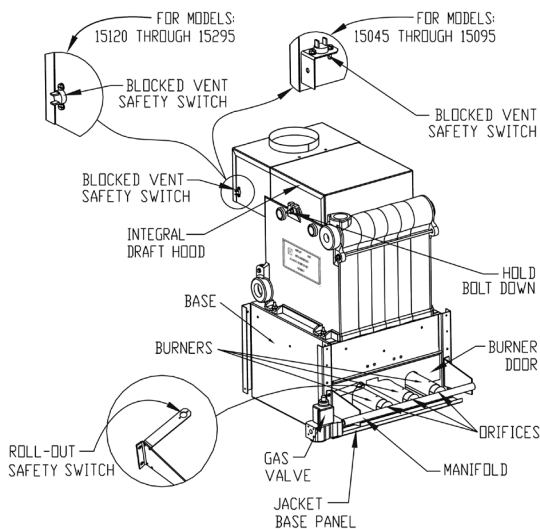
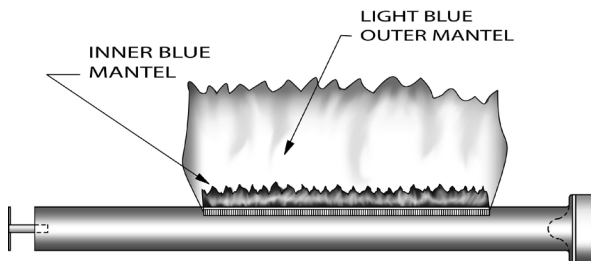

Figure 7 - Burner with Mantel



- Thermostat actuates on call for heat, completing circuit to control.
- Completed circuit to control activates circulator. Damper will close end switch inside the damper. This will complete circuit to ignition system and ignition takes place.
- Power is interrupted between control system and ignition system if boiler water temperature exceeds high limit setting on boiler mounted high limit control. Power remains off until boiler water temperature drops below high limit setting. Circulator continues to operate under this condition until thermostat is satisfied.
- Blocked flow of combustion products through boiler venting system causes blocked vent safety switch to shut main burner gas off. If boiler flueway becomes blocked, flame rollout safety switch will shut main burner gas off. See Figure 6. If either condition occurs, do not attempt to place boiler back into operation. Contact qualified service agency.
- Main burner flame should have well defined inner blue mantel with lighter blue outer mantel. See Figure 7.
- Pilot flame should envelop $\frac{3}{8}$ to $\frac{1}{2}$ inch of tip of the pilot thermocouple, ignition/sensing electrode or mercury sensor. See Figure 8.

Checking Gas Input Rate To Boiler



- Adjust gas input to boiler by removing protective cap on pressure regulator and turning screw clockwise  to increase input and counterclockwise  to decrease input.
- Set natural gas manifold pressure at approximately 3.5 inches water column. Manifold pressure is taken at outlet side of gas valve.
- To check for proper flow of natural gas to boiler, divide input rate shown on rating plate by heating value of gas obtained from local gas company. This will determine number of cubic feet of gas required per hour.
- With all other gas appliances off, determine flow of gas through meter for two minutes and multiply by 30 to get hourly rate. Make minor adjustments to gas input as described above.
- Change burner orifices if final manifold pressure varies more than plus or minus 0.3 inches water column from specified pressure.
- Primary air adjustment is not necessary, therefore air shutters are not furnished as standard equipment. Air shutters are available on request where required by local codes or conditions.

Figure 8 - Pilot

