

# MODEL GTMA NATURAL GAS AND PROPANE GAS MID EFFICIENCY CATEGORY I WARM AIR FURNACE



**ECR INTERNATIONAL LTD.**

P.O. Box 900, 6800 Base Line  
Wallaceburg, ON N8A 5E5  
Canada  
[www.ecrltd.com](http://www.ecrltd.com)

2201 Dwyer Avenue,  
Utica, New York, 13504  
USA

85 Middle Road,  
Dunkirk, New York, 14048  
USA

[www.ecrltd.com](http://www.ecrltd.com)

 An **ECR** International Brand  
An ISO 9001-2000 Certified Company



# MODEL GTMA WARM AIR FURNACE

INSTALLATION MANUAL AND OPERATING INSTRUCTIONS  
P/N# 240006133, Rev. B [01/07] • Printed in Canada • Made In Canada

## TABLE OF CONTENTS

1 - Introduction .....	2
2 - Safety Symbols and Warnings .....	2
3 - Furnace Sizing .....	6
4 - Location of Unit .....	7
5 - Combustible Clearances .....	9
6 - Ductwork .....	9
7 - Ventilation and Combustion Air .....	11
8 - Determining Combustion Air .....	16
9 - Gas Supply and Piping .....	18
10 - Conversions .....	19
11 - Electrical Specifications .....	23
12 - Low Voltage Wiring .....	25
13 - Optional Accessories .....	25
14 - Air Flow .....	28
15 - Maintenance and Troubleshooting .....	31
16 - Wiring Diagrams .....	37
17 - Replacement Parts List .....	39

PLEASE READ THIS MANUAL CAREFULLY AND KEEP IN A SAFE PLACE FOR FUTURE REFERENCE BY A SERVICE TECHNICIAN.

## 1 - INTRODUCTION

This mid efficient gas fired furnace is an upflow, horizontal left and horizontal right warm air furnace suitable for residential and light commercial heating applications from 50,000 to 100,000 BTU/Hr.

This mid efficient furnace series is CSA design certified as a Category I chimney vent central forced air furnace with all combustion air from the ambient air around the furnace. All models may be fired by natural gas or LP gas (propane) and may be field converted from natural gas to LP gas.

The furnace is shipped completely assembled. Please inspect for damage as the furnace is unpacked.

## 2 - SAFETY SYMBOLS AND WARNINGS

The following defined symbols are used throughout this manual to notify the reader of potential hazards of varying risk levels.



**INDICATES AN IMMINENTLY HAZARDOUS SITUATION WHICH, IF NOT AVOIDED, WILL RESULT IN DEATH OR SERIOUS INJURY.**



**INDICATES A POTENTIALLY HAZARDOUS SITUATION WHICH, IF NOT AVOIDED, COULD RESULT IN DEATH OR SERIOUS INJURY.**



**Indicates a potential hazardous situation which, if not avoided, MAY result in minor or moderate injury. It may also be used to alert against unsafe practices.**

**IMPORTANT:** Read the following instructions COMPLETELY before installing!!



**IF THE INFORMATION IN THESE INSTRUCTIONS IS NOT FOLLOWED EXACTLY, A FIRE OR EXPLOSION MAY RESULT, CAUSING PROPERTY DAMAGE, PERSONAL INJURY OR LOSS OF LIFE.**



**THIS PRODUCT MUST BE INSTALLED BY A LICENSED PLUMBER OR GAS FITTER WHEN INSTALLED WITHIN THE COMMONWEALTH OF MASSACHUSETTS.**





**FOR YOUR SAFETY**

**DO NOT STORE OR USE GASOLINE OR OTHER FLAMMABLE VAPORS AND LIQUIDS, OR OTHER COMBUSTIBLE MATERIALS IN THE VICINITY OF THIS OR ANY OTHER APPLIANCE.**

**WHAT TO DO IF YOU SMELL GAS**

- **DO NOT TRY TO LIGHT ANY APPLIANCE.**
- **DO NOT TOUCH ANY ELECTRICAL SWITCH; DO NOT USE ANY PHONE IN YOUR BUILDING.**
- **IMMEDIATELY CALL YOUR GAS SUPPLIER FROM A NEIGHBOR'S PHONE, OR A CELLULAR PHONE FROM A LOCATION WELL AWAY FROM THE BUILDING. FOLLOW THE GAS SUPPLIER'S INSTRUCTIONS.**
- **IF YOU CANNOT REACH YOUR GAS SUPPLIER, CALL THE FIRE DEPARTMENT.**
- **DO NOT RE-ENTER THE BUILDING UNTIL AUTHORIZED TO DO SO BY THE GAS SUPPLIER OR THE FIRE DEPARTMENT.**

**IMPROPER INSTALLATION, ADJUSTMENT, ALTERATION, SERVICE OR MAINTENANCE CAN CAUSE INJURY, PROPERTY DAMAGE OR LOSS OF LIFE. REFER TO THIS MANUAL.**

**INSTALLATION AND SERVICE MUST BE PERFORMED BY A QUALIFIED INSTALLER, SERVICE AGENCY OR THE GAS SUPPLIER.**



**THESE INSTRUCTIONS ARE INTENDED AS AN AID TO QUALIFIED SERVICE PERSONNEL FOR PROPER INSTALLATION, ADJUSTMENT AND OPERATION OF THIS FURNACE. READ THESE INSTRUCTIONS THOROUGHLY BEFORE ATTEMPTING INSTALLATION OR OPERATION. FAILURE TO FOLLOW THESE INSTRUCTIONS MAY RESULT IN IMPROPER INSTALLATION, ADJUSTMENT, SERVICE OR MAINTENANCE, POSSIBLY RESULTING IN FIRE, ELECTRICAL SHOCK, CARBON MONOXIDE POISONING, EXPLOSION, PROPERTY DAMAGE, PERSONAL INJURY OR DEATH.**

**SAFETY RULES**

1. Use this furnace only with type of gas approved for this furnace. Refer to the furnace rating plate.
2. Install this furnace only in dry indoor locations (protected from weather).
3. Provide adequate combustion and ventilation air to the furnace space as specified in Section 7 of this manual, *"Ventilation and Combustion Air."*
4. Combustion products must be discharged outdoors. Connect this furnace to an approved vent system only, as specified in Section 7 of this manual, *"Venting and Combustion Air."*
5. Never test for gas leaks with an open flame. Use a commercially available soap solution made specifically for the detection of leaks to check all connections as specified in Section 9 of this manual, *"Gas Supply and Piping."*
6. Always install furnace to operate within the furnace's intended temperature-rise range with a duct system, which has an external static pressure within the allowable range, as specified in Sections 3, 6, and 14 of this manual, *"Furnace Sizing," "Ductwork,"* and *"Airflow."*
7. When a furnace is installed so that the supply ducts carry air circulated by the furnace to areas outside the space containing the furnace, the return air shall also be handled by duct(s) sealed to the furnace casing and terminating outside the space containing the furnace. (Furnace for heating the home located in the attached garage, for example).
8. A gas-fired furnace for installation in a residential garage must be installed so that the burners and ignitor are no less than 18" above the floor. The furnace must be located, or protected to avoid physical damage by vehicles. (*See safety warning*).
9. This furnace is not be used for temporary heating for buildings under construction.

## CODES

1. This furnace must be installed:
  - a. In accordance with all local codes, by-laws and regulations by those authorities having jurisdiction.
  - b. In Canada, this furnace must be installed in accordance with the current CAN/CGA -B149 Installation Code for Natural Gas and Propane Installations.
  - c. In the United States, this furnace must be installed in accordance with the current ANSI Z223.1 (NFPA 54) National Fuel Gas Code.
2. Electrical connections must be made in accordance with:
  - a. Any applicable local codes, by-laws and regulations.
  - b. Canada: current edition of CAN/CSA C22.1, Canadian Electrical Code (Part 1).
  - c. United States: current edition of ANSI/NFPA 70, National Electrical Code.

Additional information may be obtained from:

Canadian Standards Association  
5060 Spectrum Way  
Mississauga, Ontario, L4W 5N6  
Phone: (416) 747-4000

American Gas Association  
400 North Capitol Street, NW, Suite 450  
Washington DC, 20001  
Phone: (202) 824-7000  
National Fire Protection Association  
1 Batterymarch Park  
Quincy, MA, 02169-7471  
Phone: (617) 770-3000

### WARNING

**DO NOT INSTALL THIS FURNACE IN A MOBILE HOME! THIS FURNACE IS NOT APPROVED FOR INSTALLATION IN A MOBILE HOME. DOING SO COULD CAUSE FIRE, PROPERTY DAMAGE, PERSONAL INJURY OR LOSS OF LIFE.**

### WARNING

**THE FURNACE CONTAINS FOIL COVERED FIBERGLASS INSULATION. INHALATION OF FIBERGLASS PARTICLES IS ASSOCIATED WITH RESPIRATORY DISEASE INCLUDING CANCER.**

### WARNING

**NATURAL GAS AND PROPANE ARE NORMALLY ODORIZED BY THE FUEL SUPPLIER. IN SOME CASES, THE ODORANT MAY NOT BE PERCEIVABLE. INSTALLATION OF UL AND ULC RECOGNIZED FUEL GAS DETECTORS INSTALLED IN ACCORDANCE WITH THEIR MANUFACTURER'S INSTRUCTIONS IS RECOMMENDED AS AN ADDITIONAL MARGIN OF SAFETY.**

### WARNING

**THE EXHAUST GASES FROM THIS FURNACE CONTAIN CHEMICALS WHICH ON SOME OCCASIONS MAY INCLUDE CARBON MONOXIDE (CO). CARBON MONOXIDE IS AN ODORLESS, TASTELESS, CLEAR COLORLESS GAS WHICH IS HIGHLY TOXIC. EVEN LOW CONCENTRATIONS ARE SUSPECTED OF CAUSING BIRTH DEFECTS AND OTHER REPRODUCTIVE HARM.**

**UL AND ULC RECOGNIZED CO DETECTORS ARE RECOMMENDED FOR ALL BUILDINGS EQUIPPED WITH FOSSIL FUEL BURNING APPLIANCES. ALL CO DETECTORS SHOULD BE INSTALLED IN ACCORDANCE WITH THEIR MANUFACTURER'S INSTRUCTIONS AND APPLICABLE LOCAL BUILDING CODES.**



**WARNING**

WHEN THIS FURNACE IS INSTALLED IN A RESIDENTIAL GARAGE, IT MUST BE INSTALLED SO THE BURNERS AND IGNITION SOURCE ARE LOCATED NO LESS THAN 18" ABOVE THE FLOOR TO PREVENT THE RISK OF IGNITING FLAMMABLE VAPORS WHICH MAY BE PRESENT IN THE GARAGE.

THE FURNACE MUST BE LOCATED OR PROTECTED TO AVOID PHYSICAL DAMAGE BY VEHICLES.

FAILURE TO HEED THESE WARNINGS CAN CAUSE A FIRE OR EXPLOSION, RESULTING IN PROPERTY DAMAGE, PERSONAL INJURY OR LOSS OF LIFE.

**FIGURE 1 - FURNACE DIMENSIONS AND CLEARANCE TO COMBUSTIBLES**

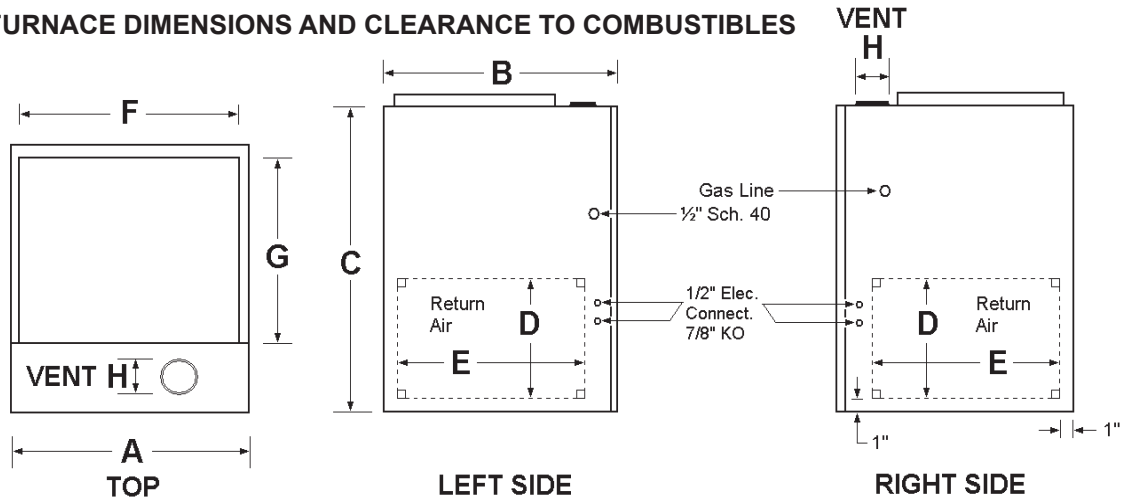

**TABLE A - FURNACE DIMENSIONS**

Model	Width A	Depth B	Height C	Vent H	Supply Air (F x G)	Return Air (D x E)
50	17½"	29¼"	36"	4"	16½" x 20"	15" x 23½"
70	17½"	29¼"	36"	4"	16½" x 20"	15" x 23½"
85	21¼"	29¼"	36"	4"	20¼" x 20"	15" x 23½"
100	21¼"	29¼"	36"	4"	20¼" x 20"	15" x 23½"

**TABLE B - FURNACE CLEARANCES TO COMBUSTIBLES**

Surface	Upflow	Horizontal	
Top	1"	2"	
Front	3"	3"	
Flue Pipe C Vent	6"	6"	
Flue Pipe B Vent	1"	1"	
Back	0"	0"	
Side or End	0"	Supply	Return
		6"	0"
Floor	Combustible	Combustible	

### 3 - FURNACE SIZING

The maximum hourly heat loss for each heated space shall be calculated in accordance with the procedures described in the manuals of the *Heating, Refrigeration and Air Conditioning Institute of Canada (HRAI)*, or by any other method which is suitable for local conditions, provided the results obtained are in substantial agreement with, and not less than those obtained using the procedure described in their manuals.

**FIGURE 1 - FURNACE COMPONENTS**

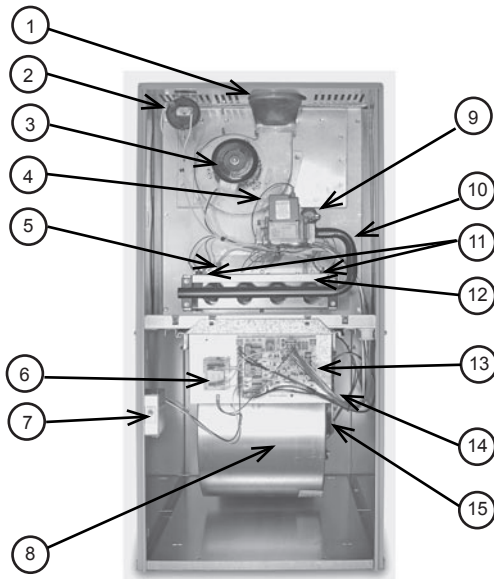

- |                                  |                                  |
|----------------------------------|----------------------------------|
| 1. Vent Connector                | 9. High Temperature Limit        |
| 2. Pressure Switch               | 10. Burner Assembly              |
| 3. Induced Draft Blower (Ventor) | 11. Flame Roll-out Switch (2)    |
| 4. Gas Valve                     | 12. Igniter                      |
| 5. Flame Sensor                  | 13. Integrated Control Board     |
| 6. Transformer for 24 VAC        | 14. Blower Motor Start Capacitor |
| 7. Door Switch and Junction Box  | 15. Blower Motor                 |
| 8. Blower                        |                                  |

In the United States, "*Manual J - Load Calculation*," published by the Air Conditioning Contractors of America, describes a suitable procedure for calculating the maximum hourly heat loss.

If the installation is a retrofit application, do not rely on the capacity of the existing heating equipment as a method to size the new furnace. Many of the heat transfer multiples listed in earlier versions of load calculation manuals were much higher than those listed in more recent editions. It is possible

that energy saving measures have been completed since the installation of the existing furnace. This might include additional insulation in the attic or walls, the application of sprayed foam insulation, the addition of storm windows and doors, weatherstripping, caulking, etc.

Many of the older furnaces were equipped with large belt drive blower systems, operating at low RPM's. If replacing an existing furnace, be sure that the existing ductwork can handle the amount of airflow necessary for a reasonable temperature rise. Most older gas furnaces operated with a system temperature rise of 70 - 100°F. This series of furnaces are designed to be operated with a system temperature rise ( $\Delta T$ ) of 35 - 65°F or 30 - 60°F. If the furnace selected has an identical output capacity as the original furnace, a substantial increase in system air flow will be required. See Tables 1A and 1B (*below*) and the airflow characteristics in Section 20 of this manual, "*Airflow*."

**TABLE 1A - RANGE OF TEMPERATURE RISE**

Furnace Model	Temperature Rise
50,000 3 ton A/C 70,000 3 ton A/C 85,000 4 ton A/C 100,000 4 ton A/C	35 - 65°F
85,000 5 ton A/C 100,000 5 ton A/C	30 - 60°F

**TABLE 1B - AIR FLOW FOR TEMPERATURE RISE**

Furnace Model	CFM Required for a $\Delta T$ of:			
	35	45	55	65
50,000	1053	819	670	567
70,000	1433	1114	912	771
85,000	1791	1393	1140	964
100,000	2107	1639	1341	1134

Existing ductwork should be assessed for its air handling capabilities. For residential applications, the recommended air velocity of a supply air trunk duct is 700 feet per minute (fpm), and should not exceed 900 fpm. The recommended air velocity of a supply air branch run is 600 fpm, and should not exceed 900 fpm. These values are slightly lower for flexible ducting. The recommended air velocity of a return air trunk duct is 600 fpm, and should not exceed 700 fpm. The recommended and maximum air velocity of a return air branch 600 fpm.

The "Equal Friction Chart," as published by ASHRAE and HRAI, is the basis for the various air duct calculators available through heating supply companies. Following the air velocity guide lines, according to the "Equal Friction Chart," or a slide rule air duct calculator, a typical 6" round duct has a capacity of approximately 100 cfm.

**NOTE:** The return air system is equally as important as the supply air system. An under-sized return air system will prevent sufficient quantities of air from reaching the supply air system; properly sized or otherwise, and will consequently reduce the service life of the furnace and its components.

## 4 - LOCATION OF UNIT

### 1. GENERAL GUIDELINES

a. Select a location where the venting can be routed between the furnace and the chimney or B-Vent with a minimum of lengths and fittings. Be sure to check that the proposed termination location will meet code requirements with respect to location and minimum clearances. (See *venting section for minimum and maximum limits.*)

b. Select a location as near as possible to the existing or proposed duct system.

c. The furnace location must permit access for servicing and be within the clearance to combustibles guidelines as marked on the appliance rating plate.

d. The furnace should be installed on a firm base when installed in the upflow position. This could typically be the concrete floor if installing the furnace in a basement.

e. If the furnace is being installed so that the return air will enter through the bottom, the perimeter of the furnace must be properly supported.

h. When installed in the horizontal position, the furnace may be supported from the bottom, or suspended. (Figure 3)

j. If the furnace is to be installed in a commercial (repair) garage, the burners and ignition source must be a minimum of 4½ feet (1375 mm) above the floor. The furnace must be protected from physical damage by metal barriers or other acceptable means.

### 2. OTHER CONSIDERATIONS

a. If the furnace is to be located in an area where the combustion air is laden with chemical compounds such as bromine, chlorine or fluorine, as may be found in swimming pool chemicals, laundry detergents, etc., use outdoor air for combustion. These compounds when exposed to flame, form acids which attack the heat exchanger and other components.

A partial list of these contaminants would include:

- Aerosols, particularly CFC based aerosols
- Air fresheners
- "Airplane" glue and similar cements
- Ammonia, as is commonly found in permanent wave solutions used in women's hair dressing salons
- Anti-static fabric softeners used in clothes dryers
- Carbon tetrachloride

**FIGURE 3 - SUGGESTED METHOD FOR SUSPENDING HORIZONTAL FURNACE**

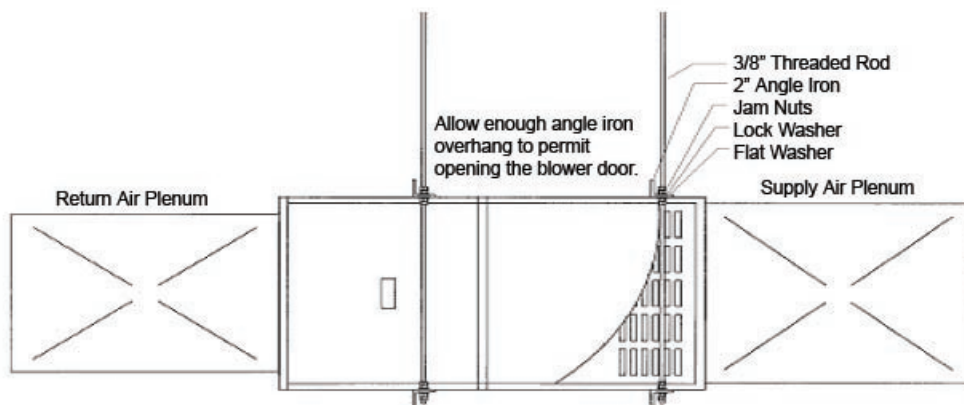

- Chlorinated cleaners and waxes
- Chlorine and bromine based swimming pool chemicals and treatments
- De-icing salts or chemicals, rock salt, etc.
- Dry cleaning solutions such as perchloroethylene
- Halogen based refrigerants including R-12 and R-22
- Hydrochloric acid, muriatic acid, or other acid based masonry washing compounds
- Polyurethane and similar derivatives fumes
- Printer's inks, paint removers, furniture strippers, varnishes, varsol, toluene, etc.
- Water softener salts and chemicals

**IMPORTANT:** This furnace is not to be used for temporary heating of buildings or structures under construction.

b. If this furnace is to be installed in an area over a finished ceiling or living area, install a field fabricated auxiliary drain pan under the furnace to protect that area from accidental condensate spills. The auxiliary pan should be large enough to collect accidentally spilled condensate from the air conditioning evaporator coil assembly if applicable.

**NOTE:** These furnaces are approved for installation in attics, alcoves, utility rooms, closets and crawl spaces. If this furnace is to be installed in a utility room, be sure that it is located in such a way as to allow access for servicing or the removal of the other appliance (hot water heater, for example).

c. If the furnace is installed in a garage, the burners must be a minimum of 18 inches above the floor.

d. If the furnace is to be installed in a commercial (repair garage), the burners must be a minimum of 4.5 feet above the floor.

e. The furnace must be protected from physical damage by metal barriers or other acceptable means.

### 3. INSTALLATION IN UPFLOW OR HORIZONTAL POSITIONS

**UPFLOW INSTALLATION:** This furnace comes assembled for installation in the upflow position and ready for vertical venting. In the event that the furnace will be installed in another position, the following guidelines should be followed.

**HORIZONTAL INSTALLATION:** The furnace must be supported in such a way as to not allow twisting or sagging of the cabinet. Maintain clearances to combustibles as outlined in Figure 1, Table B.

**NON-SUSPENDED INSTALLATION:** Maintain clearances to combustibles as outlined in Figure 1, Table B. The furnace must be supported in such a way as to not allow twisting or sagging of the cabinet.

**SUSPENDED INSTALLATION:** Maintain clearances to combustibles as outlined in Figure 1, Table B. The furnace may be suspended by field fabricating a cradle of angle iron and threaded rod. Secure the furnace with 2" minimum slotted angle or equivalent as shown in Figure 3. The furnace must be supported in such a way as to not allow twisting or sagging of the cabinet. Position the supports so as to not interfere with accessing the burner and blower compartments.

A ½" clearance will be required between the plenum and the combustible material. If installed on a non combustible material, zero clearance is required.

**IMPORTANT:** If the furnace and air conditioner is above a finished space, install a drain pan underneath the unit.

**NOTE:** It is not permissible to use a rear return on this appliance. Use only side and end returns.

### 4. AIR CONDITIONING

This furnace may be used as part of an air conditioning system. The furnace wiring and control system is "air conditioning ready." There are the following factors to consider:

- The air conditioning evaporator coil must be downstream of the heat exchanger. The cooled air passing over the warm ambient air inside the heat exchanger tubes can cause condensation inside the tubes, resulting in corrosion and premature failure.
- A parallel duct system can be installed to direct the air from the furnace through the evaporator coil only. Use dampers or other means to bypass the heat exchanger. If (summer/winter) dampers are used, they should be interlocked to prevent system operation unless the dampers are in the full open or full closed position.



## 5 - COMBUSTIBLE CLEARANCES

Figure 1 Table B provides the certified clearances to combustibles and dimensional information. Also see the appliance rating plate affixed to the furnace for specific model number, serial number and clearance to combustibles information.

**IMPORTANT:** This furnace requires a minimum of 24" of front clearance for service purposes. For this purpose, service clearance takes precedence over clearance to combustibles.



**THIS FURNACE IS DESIGN CERTIFIED FOR INSTALLATION ON COMBUSTIBLE FLOORS. THIS SHALL BE INTERPRETED AS A WOOD FLOOR ONLY.**

**THE FURNACE MUST NOT BE INSTALLED DIRECTLY ON CARPETING, TILE, OR OTHER COMBUSTIBLE MATERIAL EXCEPT WOOD.**

**INSTALLATION ON COMBUSTIBLE MATERIAL CAN RESULT IN FIRE, CAUSING PROPERTY DAMAGE, PERSONAL INJURY OR DEATH.**



**COMBUSTIBLE MATERIAL MUST NOT BE PLACED ON OR AGAINST THE FURNACE JACKET.**

**THE AREA AROUND THE FURNACE MUST BE KEPT CLEAR AND FREE OF ALL COMBUSTIBLE MATERIALS INCLUDING GASOLINE AND OTHER FLAMMABLE VAPORS AND LIQUIDS.**

**PLACEMENT OF COMBUSTIBLE MATERIALS ON, AGAINST OR AROUND THE FURNACE JACKET CAN CAUSE AN EXPLOSION OR FIRE RESULTING IN PROPERTY DAMAGE, PERSONAL INJURY OR LOSS OF LIFE.**

**THE HOMEOWNER SHOULD BE CAUTIONED THAT THE FURNACE AREA MUST NOT BE USED AS A BROOM CLOSET OR FOR ANY OTHER STORAGE PURPOSE.**

## INSPECTION / ACCESS PANEL

If an air conditioning coil is not to be used in the supply air plenum, it is recommended that the outlet duct be provided with a removable access panel which is accessible when installed so the heat exchanger may be viewed for possible openings using light assistance or a probe that can be inserted for sampling the air stream. The access cover must be fabricated in such a manner as to prevent leaks.

## 6 - DUCTWORK

Proper airflow is required for the correct operation of this furnace. Insufficient airflow may cause erratic operation, could cause the furnace to cycle on the high temperature limit, and may damage the heat exchanger. Excessive airflow may result in an excessively noisy duct system and may result in undesirable consequences such as creating uncomfortable drafts and causing drapes or curtains to blow around.

If air conditioning is to be used with the furnace, the duct system must be capable of delivering the correct amount of airflow for each system.

The ductwork should be sized and constructed in accordance with accepted industry standards. Duct sizing and construction information may be obtained from:

- A.C.C.A. (Air Conditioning Contractors of America)
- A.S.H.R.A.E. (American Society of Heating, Refrigeration and Air Conditioning Engineers)
- H.R.A.I. (Heating, Refrigerating and Air Conditioning Institute (Canada))
- S.M.A.C.N.A. (Sheet Metal and Air Conditioning Contractors' National Association (United States))

All of the above professional organizations have duct sizing manuals available.

The total static pressure drop of the air distribution system (including filters) should not exceed 0.5" w.c.

**⚠ WARNING ⚠**

DO NOT ALLOW GAS PIPING TO BE ROUTED THROUGH JOIST SPACES THAT ARE USED FOR RETURN AIR PURPOSES. DO NOT USE JOIST SPACES FOR RETURN AIR PURPOSES IF THE JOIST SPACE ALREADY CONTAINS PLUMBING STACKS, CHIMNEY COMPONENTS, ETC. UNLESS THE PORTION USED FOR RETURN AIR PURPOSES CAN BE COMPLETELY ISOLATED FROM PORTIONS WITH OTHER USAGES.

**⚠ WARNING ⚠**

NEVER ALLOW THE PRODUCTS OF COMBUSTION FROM THE FLUE TO ENTER THE RETURN AIR OR SUPPLY AIR DUCTWORK.

ALL RETURN AIR DUCTWORK MUST BE ADEQUATELY SEALED AND SECURED TO THE FURNACE WITH SHEET METAL SCREWS. TAPE THE SHEET METAL SEAMS IN THE VICINITY OF THE FURNACE WITH DUCT TAPE OR SIMILAR MATERIAL.

WHEN THE FURNACE IS MOUNTED ON A PLATFORM WITH RETURN AIR THROUGH THE BOTTOM, IT MUST BE SEALED AIR TIGHT BETWEEN THE FURNACE AND THE RETURN AIR PLENUM. THE FLOOR OR PLATFORM MUST PROVIDE SOUND PHYSICAL SUPPORT OF THE FURNACE WITHOUT SAGGING, CRACKS OR GAPS AROUND THE BASE, PROVIDING A SEAL BETWEEN THE SUPPORT AND THE BASE.

Models capable of 5 tons of airflow must have dual return air inlets for optimal airflow and air filtration. If not specifically stated by the filter manufacturer, for effective air filtration assume a maximum velocity of 300 FPM for disposable type filters or 600 FPM for permanent type air filters.

**GUIDE:**  $Filter\ free\ area\ (in^2) = 144 \times (CFM / desired\ velocity\ (FPM))$

**IMPORTANT:** Some high efficiency filters have a greater than normal resistance to airflow. This can adversely affect furnace operation.

**⚠ WARNING ⚠**

FAILURE TO PREVENT PRODUCTS OF COMBUSTION FROM BEING CIRCULATED INTO THE LIVING SPACE CAN CREATE POTENTIALLY HAZARDOUS CONDITIONS, INCLUDING CARBON MONOXIDE POISONING THAT COULD RESULT IN PERSONAL INJURY OR DEATH.

DO NOT, UNDER ANY CIRCUMSTANCES, CONNECT RETURN OR SUPPLY AIR DUCTWORK TO OR FROM ANY OTHER HEAT PRODUCING DEVICE SUCH AS A FIREPLACE INSERT, STOVE, ETC. DOING SO MAY RESULT IN FIRE, CARBON MONOXIDE POISONING, EXPLOSION, PERSONAL INJURY, LOSS OF LIFE, OR PROPERTY DAMAGE.

### DUCTWORK STEPS

1. Position the furnace to minimize ductwork length and fittings.
2. Cut open a return air inlet. The choices are furnace bottom, either side, or any combination thereof (i.e., two sides or a side and the bottom).

**⚠ WARNING ⚠**

DO NOT USE THE REAR PANEL AS A RETURN AIR INLET. THERE IS INSUFFICIENT ROOM TO PERMIT ADEQUATE AIRFLOW.

In all cases, cut the inlet air opening the full width of the knockouts.

3. Connect the return air duct or filter fitting to the furnace. The connection should be sealed air tight to prevent entraining combustion gases from an adjacent fuel burning appliance, or entraining combustion air for this furnace or adjacent fuel burning appliances.
4. Ensure that there is adequate space and accessibility for air filter removal.

**NOTE:** If two return air inlets are used, both must be equipped with filters.

5. If an air conditioning evaporator coil is required, position it on the supply air side of the furnace. Ensure that no air can bypass the evaporator coil.

6. Connect the supply air plenum to the supply air outlet.

**FLEXIBLE DUCT CONNECTORS** are an effective device to prevent the transmission of mechanical noise from the furnace to other parts of the home via the ductwork. If using flexible connectors, ensure that the adjoining duct is independently supported.

## 7 - VENTILATION AND COMBUSTION AIR



### WARNING

**READ, UNDERSTAND AND FOLLOW ALL INSTRUCTIONS IN THIS SECTION. FAILURE TO PROPERLY VENT OR SUPPLY COMBUSTION AIR TO THIS FURNACE CAN CAUSE CARBON MONOXIDE POISONING, OR AN EXPLOSION OR FIRE, RESULTING IN PROPERTY DAMAGE, PERSONAL INJURY OR LOSS OF LIFE.**

## DEFINITIONS

*“Vent and Chimney”* refer to open passageways that convey vent gasses from the furnace, or its vent connector to the outside. Vents can be horizontal or vertical. When they serve only one gas appliance, they are called “dedicated” vents or chimneys. When they serve multiple gas appliances, they are called “common” vents or chimneys.

*“Vent Connector”* refers to a pipe or duct that connects the furnace to a vent or chimney. Vent connectors usually run from the furnaces vent collar to the vent or chimney. Vent connectors may have vertical and horizontal runs.

*“Venting System”* refers to a continuous open passageway from the vent collar to the outside. Venting systems usually have a vent connector(s) and a vent or chimney. Venting systems commonly serve a single furnace, or a single furnace and a hot water heater. Other multiple appliance venting systems are less common.

*“Fan Assisted Combustion System”* refers to an appliance equipped with an integral mechanical means to either draw or force products of combustion through the combustion chamber and/or heat exchanger. This series furnace uses a draft inducer to draw combustion products through the heat exchanger and is considered to have a fan-assisted combustion system. Category I furnaces with fan-assisted combustion systems must not be vented into single wall metal vents.

## GENERAL CONSIDERATIONS

The furnace is design-certified as a Category I appliance, which means that the furnace relies on the buoyancy of combustion products to vent properly. Since buoyancy decreases with temperature, the chimney size and properties are very important. An oversized chimney, or one that is exposed to the cold will not maintain the required buoyancy as well as it should, and may allow excessive condensation to form.

**IMPORTANT:** Do not vent the furnace in common with Category III or IV gas fired appliances.

The furnace must be vented in accordance with these instructions, the Venting Tables and rules published in the current editions of B149, Natural Gas and Propane Installation Code in Canada, or ANSI Z223.1 / NFPA 54, National Fuel Gas Code in the United States, and within the requirements of the codes of the local authority having jurisdiction. Refer to section 7 of B149 or ANSI 223.1/ NFPA 54 for venting requirements and details.

The furnace is not equipped with a draft hood to introduce dilution air to the chimney. The products of combustion will therefore have a higher concentration of water vapour within them.

If the furnace is the only appliance served by the chimney, a tiled masonry chimney, regardless of tile size, must not be used without a suitably sized certified chimney liner and termination. Consider dedicated venting with a B-Vent used as a liner in this case. See Dedicated Venting.



### WARNING

**SELECT APPROPRIATE VENTING MATERIALS AND ENSURE PROPER CLEARANCES TO COMBUSTIBLES. INADEQUATE VENTING OR FAILURE TO MAINTAIN PROPER CLEARANCES TO COMBUSTIBLES MAY ALLOW THE ACCUMULATION OF THE PRODUCTS OF COMBUSTION WITHIN THE BUILDING RESULTING IN FIRE, NAUSEA, OR ASPHYXIATION.**

**⚠ WARNING ⚠**

**DO NOT USE AN UNLINED MASONRY CHIMNEY TO VENT THIS FURNACE. THE USE OF AN UNLINED MASONRY CHIMNEY INCREASES THE RISK OF CONDENSATE FORMATION, WHICH MAY CAUSE THE CHIMNEY TO DETERIORATE, ALLOWING COMBUSTION PRODUCTS AND CONDENSATE TO COLLECT IN THE BUILDING.**

Multi-storey and common venting with other Category I gas-fired appliances is permitted. The venting system must be in accordance with the national gas code, B149 in Canada, ANSI Z223.1/NFPA 54 in the United States, local codes, and approved engineering practices.

**IMPORTANT:** This furnace is not to be vented in the same chimney or venting system serving a solid fuel appliance (wood or coal). If the furnace is to be vented into a chimney serving a fireplace, the fireplace opening is to be permanently sealed.

The furnace must connect to a listed chimney (B-1 Vent), or vent complying with a recognized standard, or a suitably sized, constructed and lined masonry chimney. The chimney lining method and material must comply with local requirements. Use corrosion-resistant material meeting nationally recognized standards for vent construction.

Avoid over sizing the furnace for the application. A furnace selected as close as possible for the actual building heat loss will have longer firing cycles which will reduce the potential for damaging condensate formation in the venting system.

Take the building orientation and the presence of other buildings or other nearby structures into consideration when planning the venting system location. Certain external structures could create air turbulence around the vent termination leading to downdrafts and similar venting problems.

**VENT SIZING**

The venting system, taking all appliances to be vented into consideration, must be sized in accordance with the Venting Tables and rules published in the current editions of B149, Natural

Gas and Propane Installation Code in Canada, or ANSI Z223.1 / NFPA 54, National Fuel Gas Code in the United States. An undersized venting system will not permit the complete removal of products of combustion, and an oversized venting system will not heat up quickly enough to avoid condensation formation

**INSTALLATION**

Vents and chimneys usually extend vertically with offsets not exceeding 45° from vertical. Consider all offsets greater than 45° from vertical as horizontal runs. Include their length in the total horizontal run calculation.

Horizontal runs should be as short as practical and not exceed 75% of the vent height. The vent height must be a minimum of 5 feet above the highest appliance in a Category I venting system.

Minimize vent connector horizontal runs to the extent possible for best performance. Avoid unnecessary fittings. For example, an offset constructed of 45° elbows is generally better than one made of 90° elbows.

Support all horizontal sections of the venting system with pipe hangers, strap or equivalent at each joint to prevent sagging. Horizontal segments must slope upward from the furnace to vent or chimney with a minimum ¼ inch per foot.

When the vent tables from B149 or ANSI 223.1/NFPA 54 permit more than one pipe diameter for the vent or vent connector, the smallest size is usually the best choice to help reduce the potential for condensation formation.

When using manufactured venting (B-1 Vent for example), follow the vent manufacturer's instructions. UL listed B-1 venting; both flexible and rigid are suitable venting materials for the furnace.

The installer must ensure that the venting of the furnace and all other gas appliances connected to the vent or chimney function properly.

**VENT CONNECTOR**

The furnace may be vented with a listed single wall or Type B double wall vent connector to a B-Vent or lined masonry chimney. Most United States ju-

risdictions require a minimum 28-gauge galvanized single wall vent connector. Most Canadian jurisdictions require the vent connector to have corrosion resistance equivalent to 24-gauge galvanized sheet metal.

Observe the rules concerning clearance to combustibles.

- The vent connector must be readily accessible for inspection, cleaning or replacement.
- Keep the vent connector as short as possible by locating the furnace as close as practical to the vent or chimney.
- Avoid unnecessary turns or bends that create resistance to the flow of the vent gases. Fittings such as elbows add resistance to the vent connector.
- Use Type B-vent connectors in attics, crawl spaces, or other cold areas. Install thimbles that meet clearance to combustibles requirements and local code requirements if the vent connector must pass through a wall or partition constructed of combustible material.
- The preferred method to join vent connectors to a vent or chimney is by individual connections. If two vent connectors must be joined before the vent or chimney, use a correctly sized wye or tee-wye fitting as close to the vent or chimney as practical.
- All mid efficient furnace collars are 4 inch. When the Canadian B149, or United States ANSI Z223.1 / NFPA 54 venting tables specify the use of 3 inch venting, use a 4 to 3 reducer at the furnace collar.
- Secure all single wall vent connector segments together with a minimum of two sheet metal screws per joint. Secure the vent connector to the furnace collar with a minimum of 2 sheet metal screws. Type B vent connectors do not require sheet metal screws since they have their own locking system.

## VENT TERMINATION

Terminate all vertical vents with a listed vent cap or roof assembly unless local codes require otherwise. Locate the termination in an area free of positive pressure or wind eddies. Eddies may occur when wind swirls over roof peaks. They can cause downdrafts and interfere with normal vent operation.

Some manufactured vent caps are resistant to wind and eddies; their use is recommended.

The vent termination must be a minimum of 5 feet above the highest gas appliance connection. The vent must extend a minimum of 3 feet above the point that it passes through the roof. The vent termination must be a minimum of 2 feet higher than any part of the building horizontally within 10 feet of the vent.

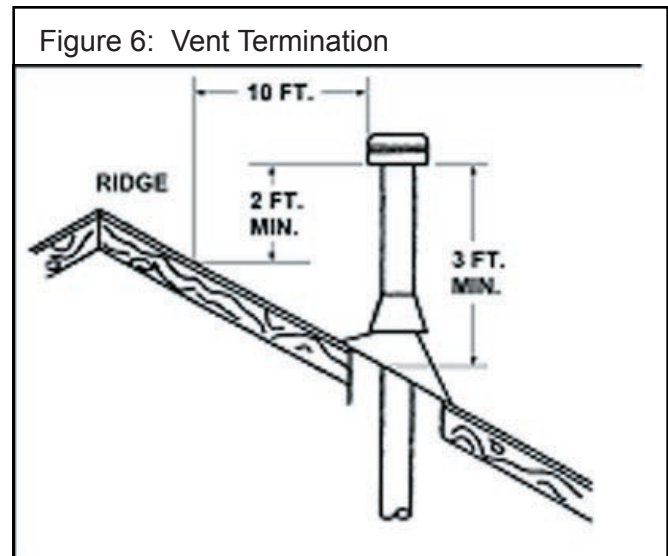

## DEDICATED VENTING

Figure 7 shows a good method to permit dedicated venting making use of B-Vent within a masonry chimney.



FAILURE TO PROPERLY TERMINATE THE VENT OR CHIMNEY SYSTEMS COULD ALLOW COMBUSTION PRODUCTS TO COLLECT INSIDE THE BUILDING CAUSING PERSONAL INJURY OR DEATH.

When using this method, provide support for the B-Vent.

**IMPORTANT:** maintain at least 1 inch clearance between the B-Vent and the chimney tile or chimney. This will help prevent the formation of condensation.

## EXISTING VENT CONSIDERATIONS

If this furnace is to replace a Category I type furnace connected to a chimney serving other appliances, steps must be taken to ensure that this furnace and the remaining appliances will vent properly after the removal of the existing furnace. There is a chance that the existing chimney will be too large.

Check the size of the existing vent or chimney. It should be sized as though this is a new installation. If it is not, undertake remedies to correct the size.

Check the condition of the existing vent or chimney. Examine vent or chimney clean-outs to make sure that they remain tightly closed when not in use. Ensure that the vent or chimney passageway is clear and free from obstructions. Look for evidence of condensation damage or deterioration in the vent or chimney. Either of these conditions indicates an inadequate vent. Missing mortar in the top few courses of brick in a masonry chimney is a definite sign of condensation damage.

If the vent or chimney is found to be damaged or inadequate, it must be repaired or replaced. The repaired or replacement vent or chimney must meet

the standards prescribed in CAN/GGA-B149, Natural Gas and Propane Installation Code in Canada or ANSI Z223.1 National Fuel Gas Code (NEPA 54), in the United States.

When the new furnace is connected to a common vent, the new furnace and the other appliances connected to the common vent must be tested individually following these steps:

1. Permanently seal any unused openings into the common vent system.
2. Visually inspect the venting system for proper size and horizontal pitch and determine that there is no blockage, restriction, leakage, corrosion, collapsed materials such as fallen bricks, or any other deficiency that could lead to an unsafe condition.
3. Insofar as practical, duplicate winter operating conditions such as closing all windows and doors in the building. If the remaining appliances are in a mechanical room, close the door to the room.
4. Close the fireplace dampers if any.
5. Turn on any appliances that exhaust air to the outdoors on maximum speed. This would include clothes dryers, range hoods, bathroom fans, etc. Attic fans or other fans used only in summer should be exempted from the test.
6. Follow the lighting instructions of the appliance being tested and turn it on to continuous operation.
7. For appliances equipped with draft hoods, test for spillage at the draft hood relief opening after 5 minutes of main burner operation. Detect for spillage using a match flame or a taper (candle).
8. After it has been proven that each appliance to remain connected to the common venting system properly vents when tested as listed above, return the windows, doors, fireplace dampers, appliances, etc. to the condition they were in prior to the test.
9. If improper venting is observed during any of the tests, the common venting system must be re-sized. In Canada, refer to the latest addition if CAN/GGA-B149, Natural Gas and Propane Installation Code. In the United States, refer to the latest ANSI Z223.1 National Fuel Gas Code (NEPA 54), or AGA-GAMA Venting Tables for Category I furnaces.

Figure 7: Dedicated Venting

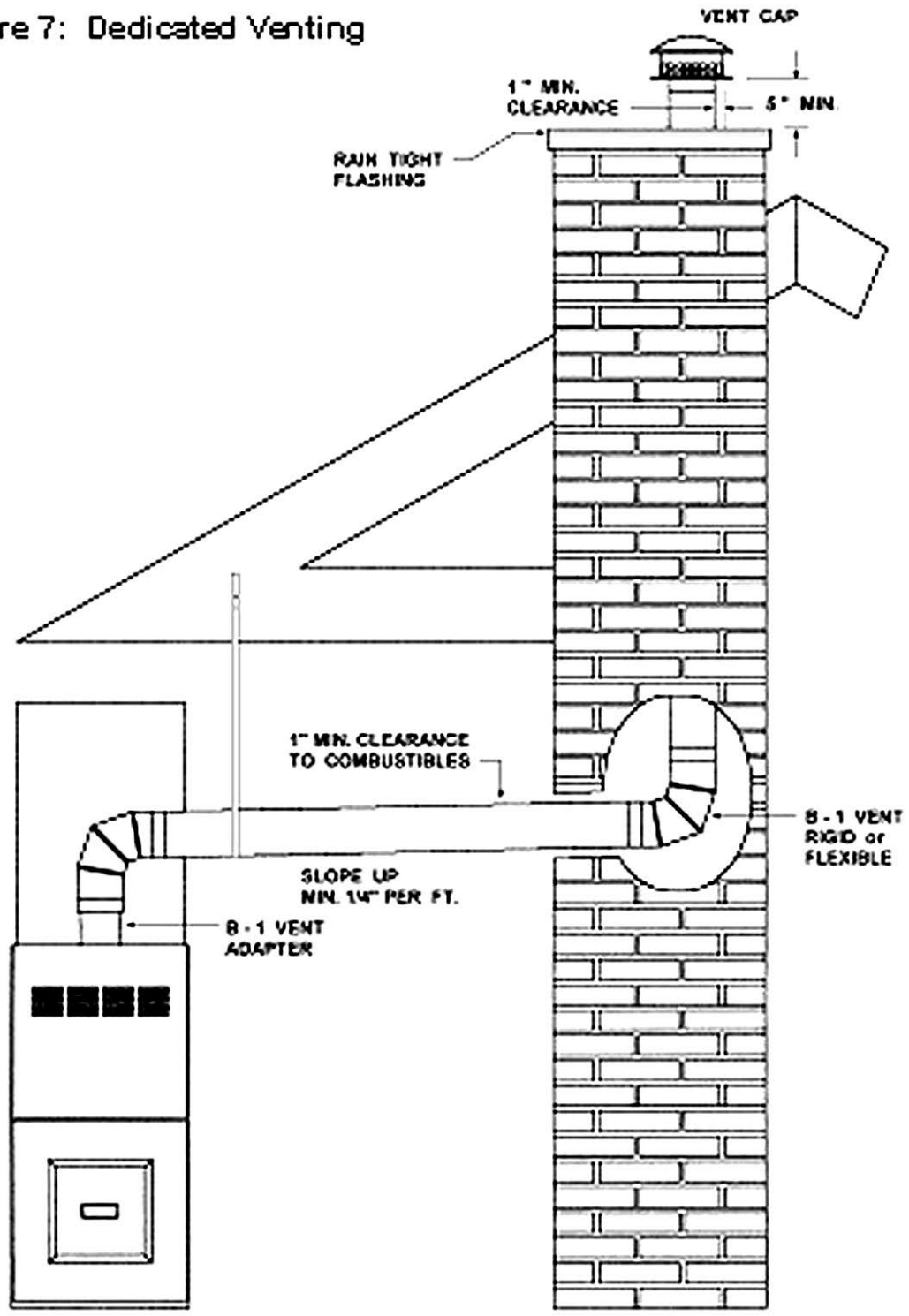

The following types of installation sites (but not limited to the following) will require OUTDOOR AIR for combustion because of chemical exposures:

- Commercial buildings
- Buildings with indoor swimming pools
- Furnaces installed in laundry rooms
- Furnaces in hobby or craft rooms
- Furnaces installed near chemical storage areas

Exposure to the following substances in the combustion air supply (but not limited to the following) will also require OUTDOOR AIR for combustion:

- Aerosols, particularly CFC based or propelled aerosols
- Air fresheners
- “Airplane Glue” and similar adhesives and cements
- Ammonia, as commonly found in permanent wave solutions used in hair dressing salons
- Anti-static fabric softeners used in clothes dryers
- Carbon tetrachloride
- Chlorinated cleaners and waxes

- Chlorine and bromine based swimming pool chemicals
- De-icing salts or chemicals (rock salt, etc.)
- Dry cleaning fluids such as perchloroethylene
- Fumes from curing polyurethane and similar substances
- Halogen based refrigerants including R-12 and R-22
- Hydrochloric acid, muriatic acid and other acid based masonry washing and curing materials
- Printer’s inks, paint removers, varnishes, var-sol, toluene, etc.
- Water softener salt and chemicals

Combustion air must be free of acid forming chemicals such as sulphur, fluorine and chlorine. These elements are found in aerosol sprays, detergents, bleaches, cleaning solvents, air fresheners, paint and varnish removers, refrigerants, and many other commercial and household products. When burned in a gas flame, vapors from these products form acid compounds. Acid compounds increase the dew point temperature of the flue products and are highly corrosive after they condense.

## 8 - DETERMINING COMBUSTION AIR

### CASE 1 - FURNACE LOCATED IN AN UNCONFINED SPACE

Unconfined space does not necessarily mean that ventilation will not have to be introduced from the outdoors, particularly in airtight homes. The minimum requirement for unconfined space is a volume of 50 cubic feet for each 1000 BTU/Hr for all fuel burning appliances located within the unconfined area.

If the amount of combustion and ventilation air is insufficient to properly operate the furnace and other fuel burning appliances within the unconfined area, it will be necessary to supply it from the outdoors based on the criteria used when calculating the air supply for a confined space.

**NOTE:** If planning to use the inside air in an unconfined space, remember to test for proper furnace operation (as well as other fuel burning appliances located within the unconfined space) with respect to adequate combustion and ventilation air with fireplace dampers open, clothes dryer running, bathroom exhaust fans on, kitchen range hood on, etc.

### CASE 2 - FURNACE LOCATED IN A CONFINED SPACE

A confined space, (any space smaller than the minimums discussed in Case 1), must have two air openings; one within 12” of the ceiling and the other

er within 12” of the floor. The air openings must be sized based on whether the combustion and ventilation air is being taken from indoors or outdoors, the method outdoor air (if used) is introduced, and taking into account any other fuel burning appliances in the confined space.

If sufficient indoor combustion and ventilation air is available for the furnace and all other fuel burning appliances, size each opening on the basis of one square inch of free area per 1000 BTU/Hr. (Figure 8)

**NOTE:** Be sure to consider all clothes dryers, bathroom fans, range hoods, etc., when making this calculation.

**FIGURE 8 - COMBUSTION/DILUTION AIR FROM HEATED INSIDE SOURCES (CASE 2)**

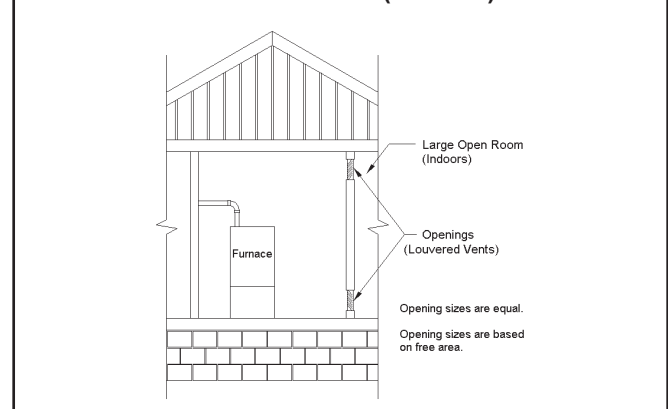



The minimum requirement for these openings is 100 square inches, even for the furnace models under 100,000 BTU/Hr.

**NOTE:** If using grilles to cover the two openings, factor in the free area of the grille. Typically, a sidewall grille will have a free area approximately 50% of its nominal size. Consequently, if the required opening is 10 x 10, it will have to be doubled if using a sidewall grille with 50% free area.

**IMPORTANT:** If an exhaust fan, fireplace, clothes dryer or any similar device is present in the indoor area from which the combustion and ventilation air will be drawn, negative pressure could be a problem if natural infiltration from the outdoors does not match the rate at which air is exhausted.

**CASE 3 - FURNACE LOCATED IN A CONFINED SPACE, OUTDOOR AIR FROM ATTIC OR CRAWL SPACE**

In this circumstance, the free area of each of the two combustion and ventilation air openings is based on a minimum of 1 square inch per 4000 BTU/Hr. In this configuration, one opening can originate from the floor drawing combustion and ventilation air from the ventilated crawl space.

The other opening may communicate freely with a ventilated the attic. If using the attic air, ensure that the opening is ducted from the ceiling high enough to be above the insulation. The attic must be adequately vented with soffit vents or gable vents (Figure 9)

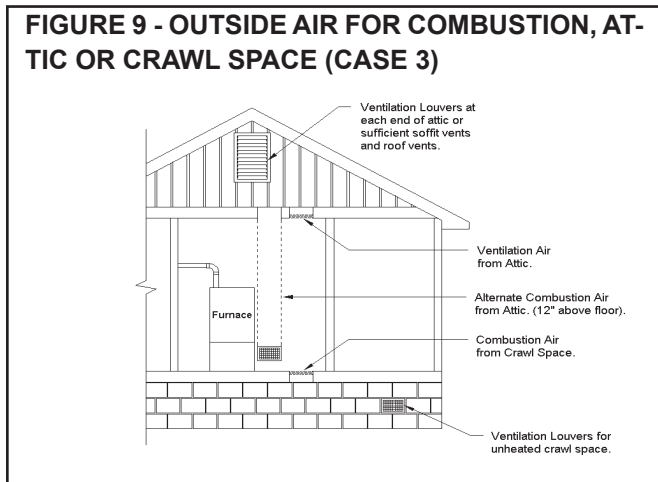

As an alternative to creating an opening in the floor to draw air from a crawl space, a duct may be dropped from the attic terminating 12” above the floor.

The following table shows minimum free areas and round pipe sizes when drawing combustion air vertically from the attic or crawl space for the furnace

only. If other fuel burning appliances are present, their combustion air and ventilation air requirements must be added to those of the furnace.

**TABLE 2 - VERTICAL AIR SUPPLY (CASE 3)**

Model	Free Area Ea. Opening	Round Pipe Size
50	12.5 in. <sup>2</sup>	4 in.
70	17.5 in. <sup>2</sup>	5 in.
85	21.25 in. <sup>2</sup>	6 in.
100	25 in. <sup>2</sup>	6 in.

**IMPORTANT:** If the attic has an exhaust fan (power vent), it may create a negative pressure sufficiently large enough to prevent the attic from being an effective source of combustion and ventilation air. Powered attic fans do not customarily run during the heating season; however, some are controlled by a humidistat as well as a thermostat, which may allow some operation during the heating season. Preventative measures may include obtaining outdoor air from elsewhere or interlocking the attic exhaust fan with the furnace such that the two cannot operate simultaneously.

**CASE 4: FURNACE LOCATED IN A CONFINED SPACE, OUTDOOR AIR DUCTED HORIZONTALLY**

Similar to Case 3, outdoor air for combustion and ventilation may be drawn through horizontal ducting. The free area for each opening is calculated on the basis of a minimum of 1 square inch per 2000 BTU/Hr input.

The following table shows minimum free areas and round pipe sizes when drawing combustion air horizontally from the outdoors for the furnace only. If other fuel burning appliances are present, their combustion air and ventilation air requirements must be added to those of the furnace.

**TABLE 3 - HORIZONTAL AIR SUPPLY (CASE 4)**

Model	Free Area Ea. Opening	Round Pipe Size
50	25 in. <sup>2</sup>	6 in.
70	35 in. <sup>2</sup>	7 in.
85	42.5 in. <sup>2</sup>	8 in.
100	50 in. <sup>2</sup>	8 in.

**IMPORTANT:** If grilles are used on the outside wall, they must be sized properly. Most sidewall grilles have only 50% free area. In the case of a 100, 000 BTUH appliance, which requires a pair of 8" round pipes to obtain sufficient combustion and ventilation air, the duct could be an equivalent rectangular duct; 8" x 7" for example. Based on 50% free area for the inlet grilles, the actual grille size would have to be 14" x 8" or its equivalent. A transition may be used to reduce to the smaller duct size if necessary.

**IMPORTANT:** The outdoor grilles must be installed in a location where they will not be obstructed in any manner

**FIGURE 10 - OUTDOOR AIR FOR COMBUSTION, HORIZONTAL (CASE 4)**

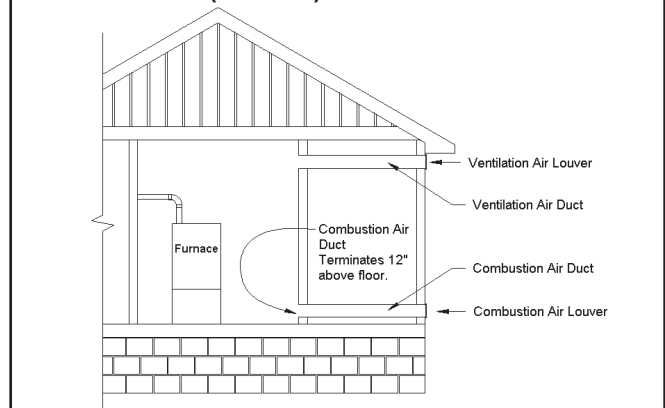

## 9 - GAS SUPPLY AND PIPING

### GAS SUPPLY



**THIS FURNACE IS FACTORY EQUIPPED TO BURN NATURAL GAS ONLY.**

**CONVERSION TO LP GAS REQUIRES SPECIAL NATURAL GAS TO LP CONVERSION KIT.**

**FAILURE TO USE THE PROPER CONVERSION KIT CAN CAUSE FIRE, EXPLOSION, CARBON MONOXIDE POISONING, PROPERTY DAMAGE, PERSONAL INJURY OR LOSS OF LIFE.**

**IMPORTANT:** Conversion of this furnace requires specialized equipment. Conversion must be completed by a trained and qualified installer, service agency or gas supplier.

**IMPORTANT:** Connect this furnace only to gas supplied by a commercial utility or supplier. Private gas wells do not generally provide gas with consistent, uniform and predictable heating values and densities. Many non-commercial wells contain impurities such as sulphur, which may damage the furnace. This furnace cannot operate properly or safely using fuels outside normal commercial standards.

### GAS PIPING

In Canada, the gas piping should be installed in accordance with CAN/CGA-B149.1 and 2, and in accordance with any local codes.

In the United States, the gas piping should be installed in accordance with NFPA 54 / ANSI Z223.1 and any local codes.

If local codes allow the use of a flexible gas appliance connector, always use a new listed connector. Do not use a connector, which has previously served another gas appliance.

The gas piping may enter the furnace from either side through a knockout provided on both side panels. Simply remove the knockout from the desired panel which gas pipe is to enter from.

Install a BMI ground joint union between the gas valve and the side panel to allow easy removal of the burner for service purposes.

**IMPORTANT:** Always use a backup wrench to prevent twisting of the control assembly and gas valve. Any strains on the gas valve can affect positioning of the orifices relative to the burners. This could result in faulty burner operation.

Install a manual gas shut-off valve and dirt pocket as close to the furnace as possible. Some local codes call for the manual gas shut-off valve to be located between 4 to 5 feet above floor level to prevent tampering by small children. Ensure that the valve is readily accessible.

**IMPORTANT:** Ensure that the manual shut-off valve and gas valve are not subjected to high pressures.



### WARNING

**DISCONNECT THE MANUAL SHUT-OFF VALVE AND GAS VALVE DURING ANY PRESSURE TESTING THAT EXCEEDS ½ P.S.I.G. (3.45 KPA).**

### GAS INLET PRESSURE

The natural gas inlet supply pressure should be 5" to 7" w.c. (7" w.c. recommended). The LP gas inlet supply pressure should be 11" to 14" w.c. (12" w.c. recommended). These pressures must be maintained while all other gas fired appliances are operating at maximum conditions.

**IMPORTANT:** Do not exceed 14" w.c. inlet pressure with either fuel.

The gas valve has an adjustable internal regulator for controlling burner manifold pressure. Burner manifold pressure is listed on the furnace rating plate.

### LEAK TESTING

All new gas piping installations should be pressure tested as specified by CAN/CGA-B149.1 & 2, or NFPA 54 ANSI Z223.1 or ANSI/NFPA 58, "Standard

for the Storage and Handling of Liquefied Petroleum Gases."

Gas piping that has not been pressure tested, from the manual shut-off valve to the furnace gas valve for example, should be leak tested using an electronic combustible gas detector, a commercially prepared leak detector, or other locally approved method. A leak detector solution can be prepared by mixing a small quantity of dish detergent with water and daubing it onto the gas piping, especially the joints.

### PURGING GAS LINES



### WARNING

**NEVER PURGE A GAS LINE INTO THE COMBUSTION CHAMBER.**

**NEVER USE A MATCH, TAPER, CIGARETTE LIGHTER, FLAME OR ANY OTHER IGNITION SOURCE TO CHECK FOR LEAKS IN A GAS LINE.**

**FAILURE TO ADHERE TO THIS WARNING CAN CAUSE A FIRE OR EXPLOSION RESULTING IN PROPERTY DAMAGE, PERSONAL INJURY, OR LOSS OF LIFE.**

### 10 - CONVERSIONS

**HIGH ALTITUDE:** In Canada, the furnace may be converted for high altitude (2000-4500 feet) by changing the burner orifices. The *Conversion Kit* part number 550001512 contains both natural gas and LP gas orifices. (Table 4)

In the United States, the modifications for high altitude are based on a 4% reduction of input capacity for every 1000 feet above 2000 feet above sea level. Table 5 (next page) illustrates the impact of altitude for selected elevations. Consult with local fuel suppliers or authorities to determine local regulations or customs.

**NATURAL TO LP GAS:** This series furnace is manufactured as a natural gas (sea level) appliance that may be converted to LP gas through use of the *Conversion Kit* part number 550001345. This kit contains the orifices needed for all models, the regulator spring for the gas valve, and a label to affix adjacent to the appliance rating plate to alert subsequent service technicians of the conversion.

**LP TO NATURAL GAS:** Although the furnace is manufactured initially as a natural gas appliance, if, after an LP gas conversion it becomes necessary to convert back to natural gas and the original parts are unavailable, The *Conversion Kit* part number 550001512 may be obtained.

FIGURE 11 - INSHOT BURNER ASSEMBLY

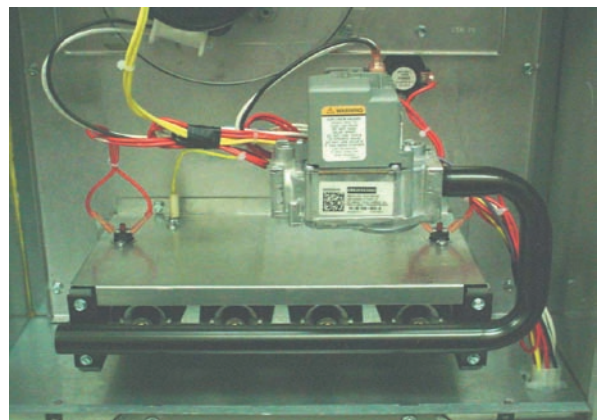

**TABLE 4 - HIGH ALTITUDE SPECIFICATIONS (CANADA)**

MODEL	ALTITUDE (FT)	INPUT BTU/HR	OUTPUT BTU/HR	ORIFICE SIZE (DMS)		QTY.
				NATURAL	LP GAS	
50	0-2000	50,000	40,000	1.95 mm	1.20 mm	3
	2000-4500	45,000	36,000	1.90 mm	1.15 mm	
70	0-2000	68,000	54,400	1.95 mm	1.20 mm	4
	2000-4500	61,200	48,960	1.90 mm	1.15 mm	
85	0-2000	85,000	68,000	1.95 mm	1.20 mm	5
	2000-4500	76,500	61,200	1.90 mm	1.15 mm	
100	0-2000	100,000	80,000	1.95 mm	1.20 mm	6
	2000-4500	90,000	72,000	1.90 mm	1.15 mm	

**TABLE 5 - HIGH ALTITUDE SPECIFICATIONS (U.S.A.)**

MODEL	ALTITUDE (FT)	ORIFICE SIZE (DMS)	
		NATURAL	LP GAS
All Models	0-2000	1.95 mm	1.20 mm
	2000-3000	49	56
	3000-4000	49	57
	4000-5000	50	57
	5000-6000	50	57
	6000-7000	50	58
	7000-8000	51	59
	8000-9000	51	59
	9000-10000	52	60

## CONVERSION STEPS

To convert from sea level to high altitude, from natural gas to LP gas, or from LP gas to natural gas, follow these steps:

1. Turn off gas supply to the furnace.
2. Shut off electrical power to the furnace.
3. Remove the front door to expose the gas train and burner assembly.
4. Unfasten the ground joint union between the gas valve and gas supply piping if applicable.
5. Unfasten the burner manifold pipe from the burner assembly. It is held in place by 2 screws on either end of the manifold pipe.
6. Remove the existing orifices with a  $\frac{7}{16}$ " socket, box or open end wrench. Install the replacement orifices. The orifice spuds are brass, and do not normally require pipe dope. A light grease may be used to lubricate the threads. The orifice spuds have taped threads. **DO NOT OVERTIGHTEN!!**
7. If completing a fuel conversion, remove the protective screw cap from the gas valve regulator adjustment. Remove the regulator adjustment screw by turning it counter-clockwise. Remove the existing regulator spring.
8. Install the new regulator spring.
9. Re-install the adjustment. Give it 4 full clockwise turns initially. Do not re-install the protective screw cap yet.
10. Re-install the burner manifold pipe assembly following steps 4, 5, and 6 in reverse order.

If, in all other respects, the furnace is ready to be fired, continue with the following steps. If not, complete the remainder of the installation and return to these steps before starting the "Start-up & Setup" section.

## SETTING THE GAS PRESSURE

FIGURE 12 - HONEYWELL GAS VALVE

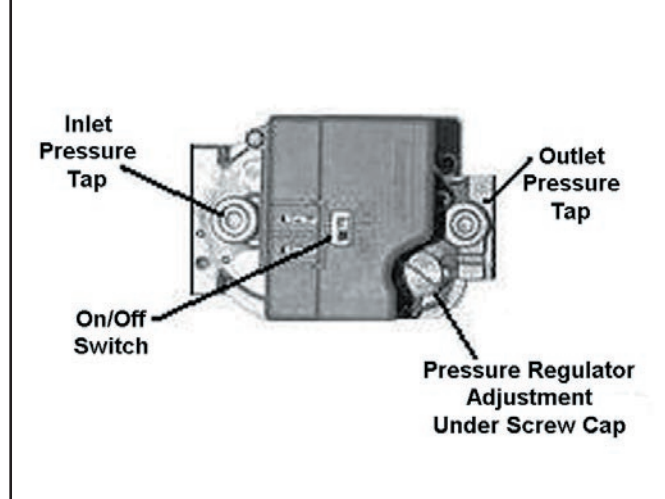

### HONEYWELL VALVE

1. Remove the allen head  $\frac{3}{16}$ " manifold pressure tap plug. Install a  $\frac{1}{8}$ " MPT to  $\frac{1}{8}$ " barb fitting.
2. Connect a U-tube manometer to the gas valve pressure tap adapter fitting. The manometer should be capable of reading 0-15" w.c.
3. Turn on the gas supply and electrical power to the furnace.
4. Start the furnace.
5. Note the gas manifold pressure. It should be  $3\frac{1}{2}$ " w.c. (Natural Gas) or  $10\frac{1}{2}$ " w.c. (LP).
6. Turn the adjustment screw clockwise to increase manifold pressure or counterclockwise to reduce manifold pressure.
7. When the correct pressure has been established, securely replace the regulator protective screw cap.
8. If the pressure remains steady and on target after tightening the cap, shut off the gas at the manual valve and remove the U-tube manometer.
9. Remove the barb adapter and replace the pressure tap plug.

If problems were encountered with obtaining enough pressure on the manifold, first examine the gas piping system to ensure that it is correctly sized. Pipe sizing is specified in CAN/CGA-B-149.1 & 2, and in NFPA 54 / ANSI Z223.1. Be sure to check for restrictions, partially closed valves, etc.

## TESTING THE GAS PRESSURE

When the installation is completed to the “*Start-up & Setup*” stage, test the gas input pressure by following these steps:

### HONEYWELL VALVE

1. Remove the allen  $\frac{3}{16}$ ” manifold pressure tap plug. Install a  $\frac{1}{8}$ ” MPT to  $\frac{1}{8}$ ” barb fitting.
2. Connect a U-tube manometer to the gas valve pressure tap adapter fitting. The manometer should be capable of reading 0-15” w.c.
3. Turn on the gas supply and electrical power to the furnace.
4. Start the furnace, and any other gas burning appliances on the same gas piping system.
5. Note the gas inlet pressure. It should be 5-7” w.c. (Natural Gas) or 11-14” w.c. (LP).
6. If working on a natural gas system, contact the gas utility. They may insist on any service regulator adjustments being made by their own staff.
7. When the correct pressure has been established, securely replace the service regulator protective screw cap.
8. Shut off the gas at the manual valve and remove the U-tube manometer.
9. Remove the barb adapter and replace the pressure tap plug.
10. Re-check, and adjust if necessary, burner manifold pressure if changes were made to the inlet pressure.

If working on a propane system, consult the fuel supplier. They too may insist on any service regulator adjustments being completed by their own staff. If permission is granted to adjust the regulator, adjustments are made in a similar fashion as the gas valve regulator. Turn the adjustment screw clockwise to increase manifold pressure or counter-clockwise to reduce manifold pressure.

### ⚠ WARNING ⚠

**ALL REGULATOR ADJUSTMENTS MUST BE DONE BY A TRAINED, QUALIFIED TECHNICIAN. IMPROPER MODIFICATIONS OR ADJUSTMENTS CAN RESULT IN FIRE OR EXPLOSION CAUSING PROPERTY DAMAGE, SEVERE PERSONAL INJURY OR LOSS OF LIFE.**

FIGURE 13 - MANIFOLD ADJUSTMENT

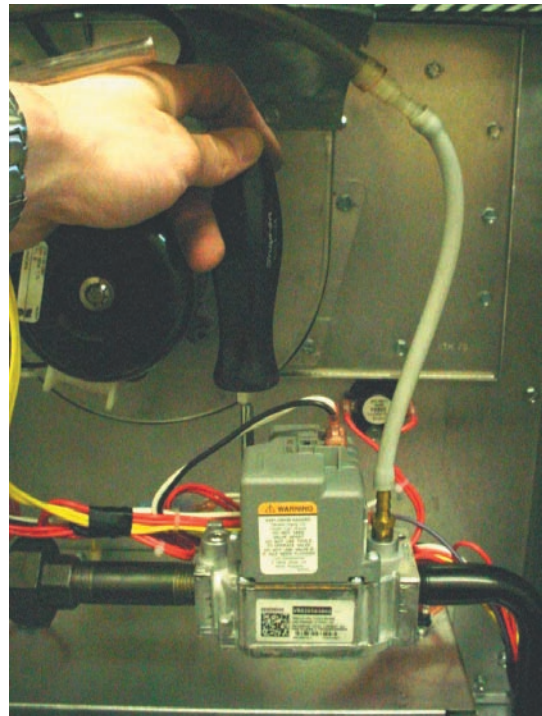

In some circumstances, high inlet pressure can be remedied with the use of an inline appliance regulator. If an inline appliance regulator is used, ensure that it has the capacity to adequately handle the gas volume required by the furnace and any other appliances receiving gas from the header serving the furnace.

**FIGURE 14 - MANOMETER MEASURING MANIFOLD GAS PRESSURE**

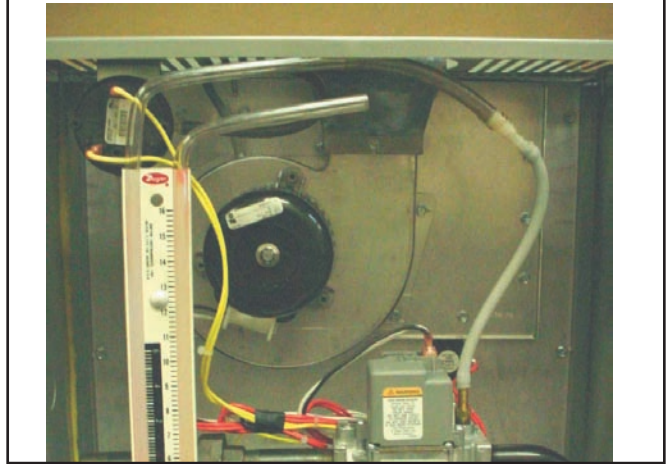

## 11 - ELECTRICAL SPECIFICATIONS

### ELECTRICAL WIRING & CONNECTIONS

Before proceeding with the electrical connections, ensure that the available electrical supply is compatible with the voltage, frequency and phase listed on the appliance rating plate.

All furnaces are rated 120 vac, 60 Hz, 1 Ø. The amperage rating is 15 amps or less.

Each furnace requires a dedicated 15 amp over-current device, either a 15 amp circuit breaker or a 15 amp Type D time delay fuse. It is permissible to connect furnace accessories such as humidifier transformers, condensate pumps and electronic air cleaners. If adding accessory equipment to the furnace circuit, ensure that the combined amperages listed on the appliance rating plates does not exceed the rating of the over-current device.



**SHUT OFF ELECTRICAL POWER AT THE FUSE BOX OR SERVICE PANEL BEFORE MAKING ANY ELECTRICAL CONNECTIONS. FAILURE TO DO SO CAN CAUSE ELECTRICAL SHOCK RESULTING IN PERSONAL INJURY OR LOSS OF LIFE.**



- **THE FURNACE CABINET MUST HAVE AN UNINTERRUPTED GROUND.**
- **A GROUND WIRE IS PROVIDED IN THE ELECTRICAL JUNCTION BOX.**
- **DO NOT USE GAS PIPING AS A GROUND.**

**FAILING TO GROUND THE FURNACE PROPERLY CAN RESULT IN ELECTRIC SHOCK RESULTING IN PERSONAL INJURY OR DEATH.**

In Canada, all electrical work must be in accordance with the latest edition of CSA-C22.1, Canadian Electrical Code Part 1, and any applicable local code.

In the United States, all electrical work must be in accordance with the latest edition of the National Electrical Code, ANSI / NFPA 70.

Although a suitably located circuit may serve as a service switch, a separate service switch is recommended. A separate service switch is necessary if the circuit breaker is in a location where accessing it would require getting close to the furnace, or if the furnace is located between the main electrical panel and the entry to the furnace room. The furnace switch (service switch) should be clearly labeled, and installed in a location where it is not likely to be mistaken as being a light switch or similar control.

**FIGURE 15 - ELECTRICAL CONNECTIONS / MOLEX CONNECTOR**

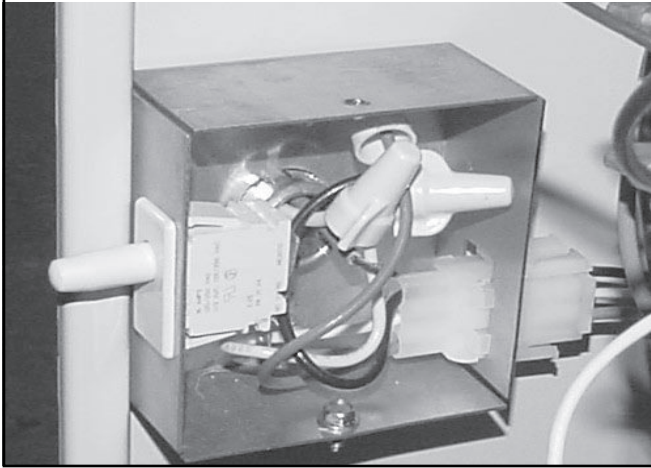

If the junction box must be moved to the right hand side of the unit:

1. Unfasten the junction box from the left hand side.
2. Remove the right side panel knock-out.
3. Remove the junction box cover hook screw and re-install it on the opposite side of the box.
4. Fasten the junction box to the right hand panel.

**NOTE:** L1 (hot) and N (neutral) polarity must be observed when making field connections to the furnace. The ignition control may not sense flame if L1 and N are reversed. The ground is also essential.

**FIGURE 16 - CONTROL BOARD WITH WIRING**

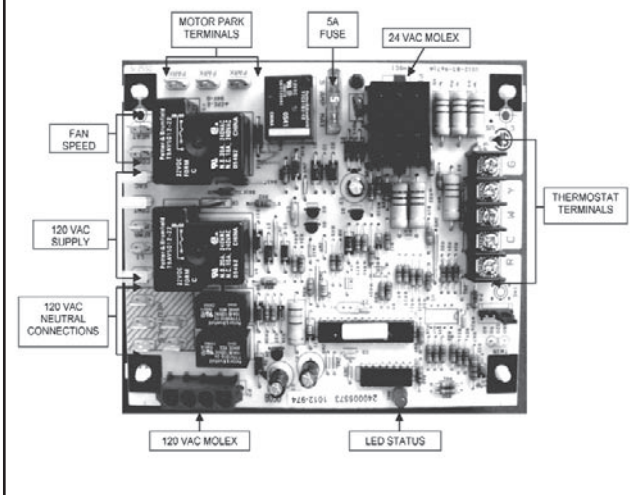

**IMPORTANT:** Electrical wiring and components must be protected from moisture including water and condensate.



**WARNING**

**THIS FURNACE IS EQUIPPED WITH A BLOWER DOOR SAFETY SWITCH. DO NOT DISABLE THIS SWITCH. FAILURE TO FOLLOW THIS WARNING CAN RESULT IN ELECTRICAL SHOCK, PERSONAL INJURY, OR LOSS OF LIFE.**

## 120V FURNACE CONNECTION

The furnace is shipped fully wired except for the connections to the house wiring. The furnace power connections are made in a junction box inside the blower compartment. The junction box is factory installed on the left hand side; however, it may be moved to the right hand side. The junction box contains a BLACK wire to be connected with L1 (hot), a WHITE wire to be connected with L2, the Neutral, and a GREEN wire to be connected to the ground.

**NOTE:** Use good quality wire nuts such as Marrette® connectors, Ideal® wire nuts, etc.

**IMPORTANT:** Use copper conductors only!!



## 12 - LOW VOLTAGE WIRING

The low voltage terminals are located in the control box mounted to the blower assembly. The furnace is air conditioning ready. Insert the thermostat and air conditioner contactor low voltage wiring through a knockout provided in the side panel above the supply voltage knockout using a field supplied bushing. Route the control wiring to the control panel to connect to the 24 volt terminal screws.

should work satisfactorily. Consult the instructions of the thermostat manufacturer for technical and installation details.

Most compatibility problems can be overcome by the use of an isolation relay. The isolation relay should be SPST with a 24 volt coil. The switch ratings should be a minimum of 0.5 amps. (Figure 17)

### THERMOSTAT

The room thermostat must be compatible with the integrated control in the furnace. Electro-mechanical thermostats should be rated 30 V / 1.5 amps.

The thermostat and control wiring should be a minimum of 18 AWG copper. Excessive lengths of wire may result in enough voltage drop to impair the proper functioning of the furnace. For thermostat wires in excess of 25 feet, use 16 AWG; 50 feet, use 14 AWG.

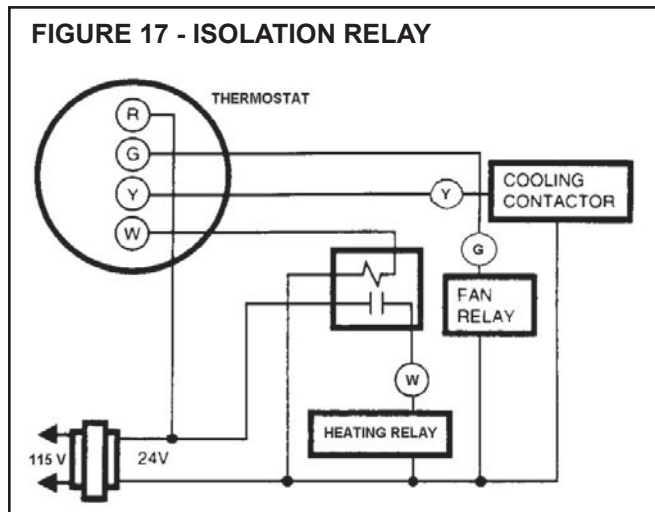

### THERMOSTAT LOCATION

The thermostat should be located approximately 5 feet above the floor, on an inside wall where there is good natural air circulation, and where the thermostat will be exposed to average room temperatures. Avoid locations where the thermostat will be exposed to cold drafts, heat from nearby lamps or appliances, exposure to sunlight, heat from inside wall stacks, etc.

**THERMOSTAT HEAT ANTICIPATOR SETTING:**  
0.1 AMP (Honeywell)

Most electronic or microprocessor based thermostats except those with "current robbing" circuits

## 13 - OPTIONAL ACCESSORIES (FIELD SUPPLIED/INSTALLED)

### ELECTRONIC AIR CLEANER

The control modules have provisions to supply power and control an electronic air cleaner rated at 120vac, 1.0 amp max. 120 volt power will be available at these terminals whenever the circulating fan is operating in the heating or cooling modes.

### POWER HUMIDIFIER

The control module has provisions to supply power and control a line voltage humidifier or the primary of a 120 / 24 volt humidifier step down transformer, rated at 120vac, 1.0 amp max.

**NOTE:** All HUM and EAC terminals are 120v. Do not directly connect 24v equipment to these terminals.

## 19 - STARTUP PROCEDURES

This furnace is equipped with a hot surface ignition (HSI) device. Each time that the room thermostat calls for heat, the HSI lights the main burners directly. See the lighting instructions on the furnace.

### TO START THE FURNACE

1. Remove the burner compartment access door.
2. Shut off the electrical power to the furnace and set the room thermostat to its lowest setting.

**IMPORTANT:** Ensure that the manual gas control switch has been in the “OFF” position for at least 5 minutes. Do not attempt to manually light the main burners.

3. Turn the gas control switch to the “ON” position.
4. Replace the burner compartment access door.
5. Restore electrical power to the furnace.
6. Set the room thermostat to a point above room temperature to light the furnace.
7. After the burners are lit, set the room thermostat to the desired temperature.

### TO SHUT DOWN THE FURNACE

1. Set the room thermostat to its lowest setting.
2. Remove the burner compartment access door.
3. Turn the gas control switch to the “OFF” position.
4. The furnace appliance shut-off valve may be closed if desired.
5. Power to the furnace must remain on for the air conditioner to work.



**SHOULD OVERHEATING OCCUR OR THE GAS BURNERS FAIL TO SHUT OFF, CLOSE THE MANUAL GAS VALVE FOR THE FURNACE BEFORE SHUTTING OFF THE ELECTRICAL POWER TO THE FURNACE. FAILURE TO DO SO CAN CAUSE AN EXPLOSION OR FIRE RESULTING IN PROPERTY DAMAGE, PERSONAL INJURY OR LOSS OF LIFE.**

**BEFORE RESTARTING THE FURNACE, CHECK ALL WIRES FOR DAMAGE.**

### SEQUENCE OF OPERATION

1. Room temperature drops causing the room thermostat heating contacts to close.
2. The induced blower (also called a power venter) begins a pre-purge cycle of 15 seconds.
3. The air proving pressure switch contact closes.
4. After the pre-purge period, the hot surface igniter heats up for 5-14 seconds.
5. The gas valve opens for a 5 second trial for ignition. The gas burners light and the igniter shuts off. *(See next section for sequence of operation in the event of a flame failure.)*
6. The circulating fan begins 30 seconds after a successful trial for ignition.
7. Furnace continues to run in this state until the room thermostat heating contacts open in response to raised room temperature.
8. With the thermostat heating contacts open, the burner flames extinguish immediately and the induced blower stops after a 5 second post-purge period. Pressure switch contacts open.
9. The circulating fan continues to run until timed out in 60 to 180 seconds, depending on the jumper selection. Factory set for 120 seconds.

### IN THE EVENT OF FLAME FAILURE:

1. Room temperature drops causing the room thermostat heating contacts to close.
2. The induced blower begins a pre-purge cycle of 15 seconds.
3. If pressure switch contact is closed and has failed to open since the last cycle, all subsequent steps will fail to occur.
4. The air proving pressure switch contact closes. If pressure switch contact fails to close, the ignition sequence will not continue.
5. After the pre-purge period, the hot surface igniter heats up for 10 seconds.

6. The gas valve opens for a 5 second trial for ignition. The gas burners light and the igniter shuts off. If the burners fail to light or if the flame is not sensed, the gas valve closes and, if there have been less than 4 trials for ignition, the sequence returns to Step 5. There is a 30 second interpurge between trials. If this was the 4<sup>th</sup> trial for ignition, the ignition sequence goes into a 60 minute soft lockout. After a 5 second post-purge, the induced blower stops and pressure switch contacts open.

7. Also, if the flame signal is lost during burner firing, the gas valve will close and the ignition sequence will begin again at Step 4. If the flame sensing signal is lost more than 3 times during a furnace cycle, the gas valve will close, the ignition sequence goes into a 5 second post-purge, and the induced blower stops. The ignition system then goes into a 60 minute lockout and reattempts the sequence at Step 4. The 60 minute lockout sequence will repeat itself indefinitely. Lowering the room thermostat setting below room temperature for approximately 3 seconds or shutting off the electrical supply to the furnace for approximately 1 seconds may interrupt the 60 minute lockout.

8. The circulating fan begins 30 seconds after a successful trial for ignition and the furnace continues to run in this state until the room thermostat heating contacts open in response to raised room temperature.

9. With the thermostat heating contacts open, the burner flames extinguish immediately, the induced blower stops after a 5 second post-purge period. The air pressure switch contacts open.

10. The circulating fan continues to run for 60 to 180 seconds, depending on the jumper selection. Factory set at 120 seconds.

## CHECKING FURNACE INPUT

The natural gas supply pressure should be a maximum of 7" w.c. and minimum of 5" w.c. The burner manifold pressure is normally set to 3.5" w.c. The input rating of the furnace is based on 1050 BTU/cu. ft. gas with a specific gravity of 0.6.

Since heating values for the gas vary geographically, the actual furnace input and output will vary accordingly. For example, natural gas with a 1000 BTU/cu. ft. heating value will reduce the input to

93% of the rated input. Natural gas with a 1100 BTU/cu. ft. heating value will increase the input to approximately 103% of the rated input. This is not usually a problem; however, adjustments to compensate for this can be made by minor adjustments to the burner manifold pressure or by changing the burner orifice size.

Any adjustments to the burner manifold pressure should be carried out with the use of a manometer or calibrated magnehelic gauge. Do not adjust the gas valve pressure regulator more than  $\pm 0.3$ " w.c.



### WARNING

Never adjust the input of the furnace to exceed the input shown on the rating plate. Failure to follow this warning could lead to premature heat exchanger failure and a hazardous furnace operating condition and result in serious bodily injury or loss of life

In the previous example where the heating value of the gas is 1100 BTU/cu. ft., the burner manifold pressure can be reduced 3% to 3.4" w.c., which is within the  $\pm 0.3$ " w.c. specification to bring the input into compliance. Refer also to "Setting the Gas Pressure" and "High Altitude in the Gas Supply & Piping" section of this manual. Contact the fuel supplier for specific gas heating content values.

If using a gas meter to check the furnace input, be sure that all gas fired appliances other than the furnace are off during the test. The formula for determining the furnace input via the gas meter test dial is:

$$\text{Input} = \frac{\text{Heating Value of Gas} \times 3600}{\text{Time in Sec. for 1 cu. ft.}}$$

where:

- input is expressed in BTU/Hr
- heating value of the gas is expressed in BTU/ft<sup>3</sup>
- and time is the number of seconds required for the test dial to indicate 1 cubic foot.

*If using a gas meter with SI (metric) units:*

- 1 cubic foot = 0.0283 cubic meters
- 1 cubic meter = 35.315 cubic feet
- 0.01 cubic meter = 0.3531 cubic feet
- 0.5 cubic meter = 1.766 cubic feet

## 14 - AIR FLOW

For proper furnace operation, air flow over the heat exchanger is of utmost importance. Insufficient airflow accelerates metal fatigue and failure in the heat exchanger and excessive airflow promotes accelerated corrosion of the heat exchanger.

**IMPORTANT:** Do not bypass this step of the start up procedures.

### TEMPERATURE RISE CHECK

When the duct system is complete and the air filter or filters are in place, determine if the airflow is correct.

1. Insert a duct thermometer in the supply air duct. The thermometer should be placed as close as practical to the furnace, but out of the "line of sight" of the heat exchanger (this prevents false readings owing to radiant heat). Ensure that the thermometer location is within the duct air stream. Avoid locations such as the inside radius of an elbow, etc.

2. Insert a duct thermometer in the return air duct as close to the furnace as practical. Ensure that the thermometer location will be unaffected by humidifier bypass ducts, etc. Choose a location well within the main air stream.

**TABLE 6 - AIR FLOW (CFM)**

MODEL		FAN HP	SPEED	EXTERNAL STATIC PRESSURE - INCHES W.C.					
Input	Available Air Conditioning Tonnage			0.10	0.20	0.30	0.40	0.50	0.60
50,000	3 Tons	G10-8 $\frac{1}{3}$	High	1328	1367	1328	1288	1284	1226
			Med	905	927	933	938	932	932
			Low	534	534	534	510	498	472
70,000	3 Tons	G10-8 $\frac{1}{3}$	High	1319	1357	1357	1394	1357	1318
			Med	943	970	980	990	1000	995
			Low	564	575	553	542	519	507
85,000	4 Tons	G10-10 $\frac{1}{2}$	High	1984	1996	1970	1922	1872	1806
			M-Hi	1606	1625	1638	1644	1621	1569
			M-Lo	1135	1153	1162	1162	1139	1106
			Low	792	797	766	730	821	673
85,000	5 Tons <sup>(1)</sup>	G12-10T $\frac{3}{4}$	High	2314	2296	2265	2215	2157	2118
			M-Hi	2039	2019	2011	1976	1948	1904
			M-Lo	1949	1934	1934	1927	1897	1868
			Low	1596	1605	1596	1596	1578	1560
100,000	4 Tons	G10-10 $\frac{1}{2}$	High	1938	1921	1883	1838	1768	1702
			M-Hi	1579	1600	1595	1579	1538	1490
			M-Lo	1092	1106	1111	1120	1058	1028
			Low	739	715	699	665	652	628
100,000	5 Tons <sup>(1)</sup>	G12-10T $\frac{3}{4}$	High	2284	2236	2178	2138	2070	2000
			M-Hi	2057	2008	1972	1943	1876	1837
			M-Lo	1944	1921	1891	1861	1814	1790
			Low	1642	1642	1624	1598	1524	1370

<sup>(1)</sup> TWO RETURNS REQUIRED

3. Operate the furnace long enough to obtain steady state conditions.

4. When the two thermometers have stabilized, usually within 5-8 minutes, compare the two readings. Subtract the return air temperature from the supply air temperature. The difference is the temperature rise, also called  $\Delta T$ .

5. Compare the measured  $\Delta T$  to the temperature rise range shown on the rating plate.

The temperature rise range should be between 35° to 65°F or 30° to 60°F as indicated on rating plate. When adjusting the temperature rise, the ideal temperature is approximately mid-range.

If the measured  $\Delta T$  is above the approved temperature range, there is too little air flow. It must be increased by selecting a faster fan speed, removing restrictions in the ductwork, or adding supply or return ductwork.

If the measured  $\Delta T$  is too low, there is too much air flow. Use a lower speed tap on the multi-speed motor.

### CALCULATING AIR FLOW

There are circumstances where it may be desirable to know the air flow delivery through the duct system, such as when estimating the amount of air flow available for air conditioning. This can be done by direct measurement with electronic or sloped manometers and velometers, or by using the formula below.

$$\text{CFM} = \frac{\text{Output}}{1.085 \times \Delta T}$$

where:

- CFM is airflow in cubic feet per minute;
- $\Delta T$  is the temperature rise; and
- Output is the furnace output capacity from the rating plate.

**NOTE:** Output will vary directly with the input. If the actual input is below the stated input, the output will be reduced in the same ratio.

### ADJUSTING BLOWER SPEEDS

If the blower speeds require adjusting, follow these steps:



**DISCONNECT THE ELECTRICAL SUPPLY TO THE FURNACE BEFORE ATTEMPTING TO CHANGE THE BLOWER SPEED. FAILURE TO DO SO COULD RESULT IN ELECTRICAL SHOCK RESULTING IN PERSONAL INJURY OR LOSS OF LIFE.**

1. Remove the blower compartment door.
2. Slide the blower assembly out far enough to access the motor electrical wiring. (Only required if motor is equipped with a power block. There are three colored wires from the motor.)
3. If the motor is equipped with a power block, remove the blue wire from the existing terminal and re-install it on the desired terminal.

**FIGURE 18 - PIGGY-BACK CONNECTOR**

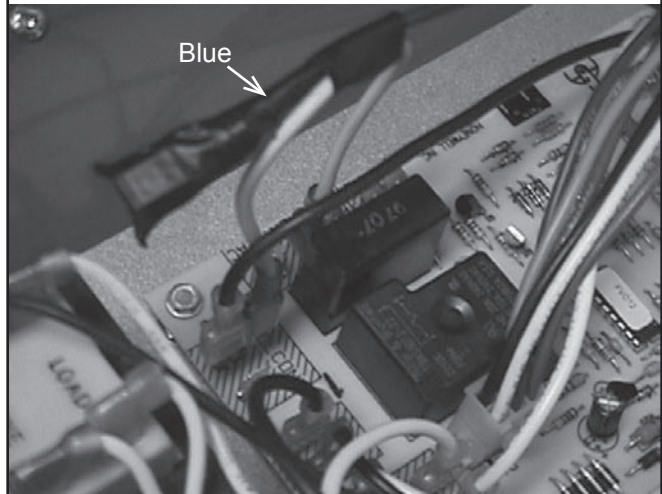

Remove blue wire from HEAT terminal, tape it off, replace it with a jumper. Connect the black wire and jumper to COOL.

If the motor has permanent leads, the speed is changed at the control module. Remove the wire from the HEAT terminal of the control module and plug in the desired wire on the HEAT terminal. When this configuration is used, the following color codes are used:

- Black** - High Speed
- Blue** - Medium-High Speed
- Yellow** - Medium-Low Speed
- Red** - Low Speed.

The unused leads are connected to the Park terminals.

**IMPORTANT:** If the heating speed and cooling speed are to be the same, remove the cooling lead from the control, tape it off, then install a piggyback connector from the control HEAT terminal to the COOL terminal.

**UNDER NO CIRCUMSTANCE MAY TWO MOTOR WINDINGS BE POWERED SIMULTANEOUSLY.**

The piggy-back connector is used for both types of motor wiring configuration; wiring block and permanent lead.

4. Slide the blower assembly back into position.
5. Re-install the blower compartment door.
6. Re-check temperature rise.

**NOTE:** Temperature rise should always be re-checked whenever blower speed is changed.

### SETTING BLOWER "OFF" TIMINGS

All the control systems allow flexibility in the FAN OFF delay function. The control is located in the blower compartment. Follow the same steps as listed in blower speed adjustment to access the control. The United Technologies control boards use a jumper to change off timing. Factory set at 120 seconds.

## 15 - MAINTENANCE AND TROUBLESHOOTING



**WARNING**

**DISCONNECT THE ELECTRICAL POWER SUPPLY TO THE FURNACE BEFORE ATTEMPTING ANY MAINTENANCE. FAILURE TO DO SO CAN CAUSE ELECTRICAL SHOCK RESULTING IN PERSONAL INJURY OR LOSS OF LIFE.**

### AIR FILTER

The filter should be inspected frequently and cleaned as necessary. We recommend a monthly inspection at first, perhaps coinciding with the arrival of the monthly fuel bill as a reminder. The frequency may be increased or decreased depending on experience and conditions.

Avoid the use of the fiberglass throw-away filters. They tend to block up quickly, which may result in higher than normal operating temperatures, and lower efficiency.

Some paper media high efficiency filters, sometimes identified as HEPA filters can do an effective and excellent filtration of the air; however, some models may also cause a large pressure drop across the filter. The contractor should access the capabilities of the duct system to deliver sufficient air flow if this type of filter is considered.

**RECOMMENDED:** Electronic air filters using electrostatic precipitation to remove dust are an excellent filtration device. A 16" x 25" model is an ideal fit with this furnace in the case of a side mounted return air inlet. The furnace control module is supplied with electrical terminals for use with electronic air cleaners.

A 16" x 25" x 1" filter kit part number 550001458 can be ordered for use on this appliance. This kit includes the filter rack and washable filter.



**CAUTION**

**Do not operate the furnace for prolonged periods of time without an air filter.**

**A portion of the dust entrained in the air may lodge in the supply air ductwork and registers. Any recirculated dust particles will be heated and charred by contact with the furnace heat exchanger. This residue will soil ceilings, walls, drapery, carpets, and other household articles.**

## LUBRICATION

Both the induced draft blower motor and circulating fan motor are ball-bearing type motors. Neither requires routine lubrication.

**IMPORTANT:** The motor bearings were pre-lubricated by the motor manufacturer. Do not attempt to lubricate them. Excess lubrication will void the warranty, shorten the service life if the motors, and will attract the buildup of dust and dirt.

The induced blower motor and circulating fan motor must be cleaned on a periodic basis by a qualified service technician. Dust buildup in the ventilation ports of the motor will cause the motor to not dissipate heat properly resulting in reduced service life.

## VENT CONNECTOR

The exhaust venting between the furnace flue pipe adapter and the chimney should be inspected periodically for sags, evidence of leakage etc. If either condition exists, contact your installation contractor, service agency or fuel supplier.



**HOLES IN THE EXHAUST PIPING OR FURNACE HEAT EXCHANGER CAN ALLOW TOXIC FUMES TO ENTER THE HOME AND CIRCULATE THROUGH THE DUCT SYSTEM RESULTING IN CARBON MONOXIDE POISONING OR DEATH. IF LEAKS ARE FOUND IN THE FURNACE HEAT EXCHANGER, IT MUST BE REPLACED.**

## OPERATING TIPS

1. Clean air filters maximize efficiency and reduce heating costs.
2. During the heating season, keep windows and doors closed to reduce the heating load on the system.
3. Avoid excessive use of kitchen exhaust hoods and other exhaust fans to reduce the heating load on the system.
4. Arrange the furniture and drapes so that the supply air registers and return air grilles are unobstructed.

5. If you have a perimeter duct system, ideally, the warm air should bathe the cold exterior walls. Avoid the use of plastic deflectors on the supply air registers which tend to short circuit the warm air straight into the return air grilles. These deflectors are often the cause of cool draughts across the floor.

6. Avoid placing heat producing appliances such as televisions, radios, lamps, etc. in a location to influence the thermostat.

7. Keep combustible articles at least 3 feet away from the furnace. Do not block access for servicing the furnace. Do not use the combustion air or exhaust piping as a hanger for clothes or anything else.

**IMPORTANT:** Never attempt to operate the furnace without the blower door and combustion compartment door in place or when the blower has failed.

## ANNUAL INSPECTION/SERVICE

The furnace must be inspected annually by a qualified installation contractor, service agency or fuel supplier. Your annual inspection will normally cover the following:

**HEAT EXCHANGER** - The heat exchanger should be inspected for corrosion and scale. The flue passages (heat exchanger tubes) should be free of scale or excessive corrosion. The heat exchanger tubing is accessible by removing burner assembly and flue box cover. A small diameter wire-handled brush can be used to clean the tubes. After clearing accumulated scale, observe the burner flames. If there appears to be flame distortion, check for signs of inadequate combustion air supply. If flame distortion continues after eliminating the blockage in the passages as the cause, it may be necessary to replace the tubular heat exchanger. The tubular heat exchanger may be field cleaned, if the tubular heat exchanger is blocked by soot or excess scale.

**BURNERS** - The burners should be inspected to ensure that they are free of deterioration, dust and debris, and properly aligned with the heat exchanger. In most cases, a simple vacuuming with a brush attachment will adequately clean the burner assembly and burner compartment.

 **CAUTION** 

Be careful when working on the burner assembly. The hot surface igniter is fragile and can break easily.

The flame sensor should be inspected and cleaned with fine steel wool or Scotch-Brite™ scrubbing pad. The wiring connection should be checked to ensure that it is tight and corrosion free.

**NOTE:** This is a critical connection. Small amounts of corrosion can significantly increase the internal resistance of the connection. A relatively small increase in resistance can result in a large decrease in flame signal.

**INDUCED BLOWER** - The induced blower motor should be inspected and cleaned if necessary. Clear any dust buildup from the ventilation ports.

**CIRCULATING FAN** - The condition of the circulating fan should be checked to ensure that it is free of excessive dust buildup, debris, etc. The mechanical fasteners should be inspected and checked for proper tightness and parts alignment. The motor ventilation ports should be cleaned if necessary to prevent restriction to cooling by air over the motor.

**ELECTRICAL** - All electrical connections should be examined to ensure that they are tight and corrosion free. Repair any connections that have become loose or corroded.

 **WARNING** 

**DISCONNECT THE ELECTRICAL POWER SUPPLY TO THE FURNACE BEFORE ATTEMPTING THIS MAINTENANCE PROCEDURE. FAILURE TO DO SO CAN CAUSE ELECTRICAL SHOCK RESULTING IN PERSONAL INJURY OR LOSS OF LIFE.**

 **CAUTION** 

**Label all wires prior to disconnection when servicing controls. Wiring errors can cause improper and dangerous operation.**

**Always verify proper operation after servicing.**

**FURNACE OPERATION** - The furnace should be cycled during the annual inspection and servicing to:

1. Test all safety related controls.
2. Determine that the temperature rise falls within the range shown on the appliance rating plate.
3. Ensure that the burner ignition is smooth and that the flames are smooth soft blue, and not impinging on the heat exchanger.



# TROUBLESHOOTING FLOWCHART

## SEQUENCE OF OPERATION

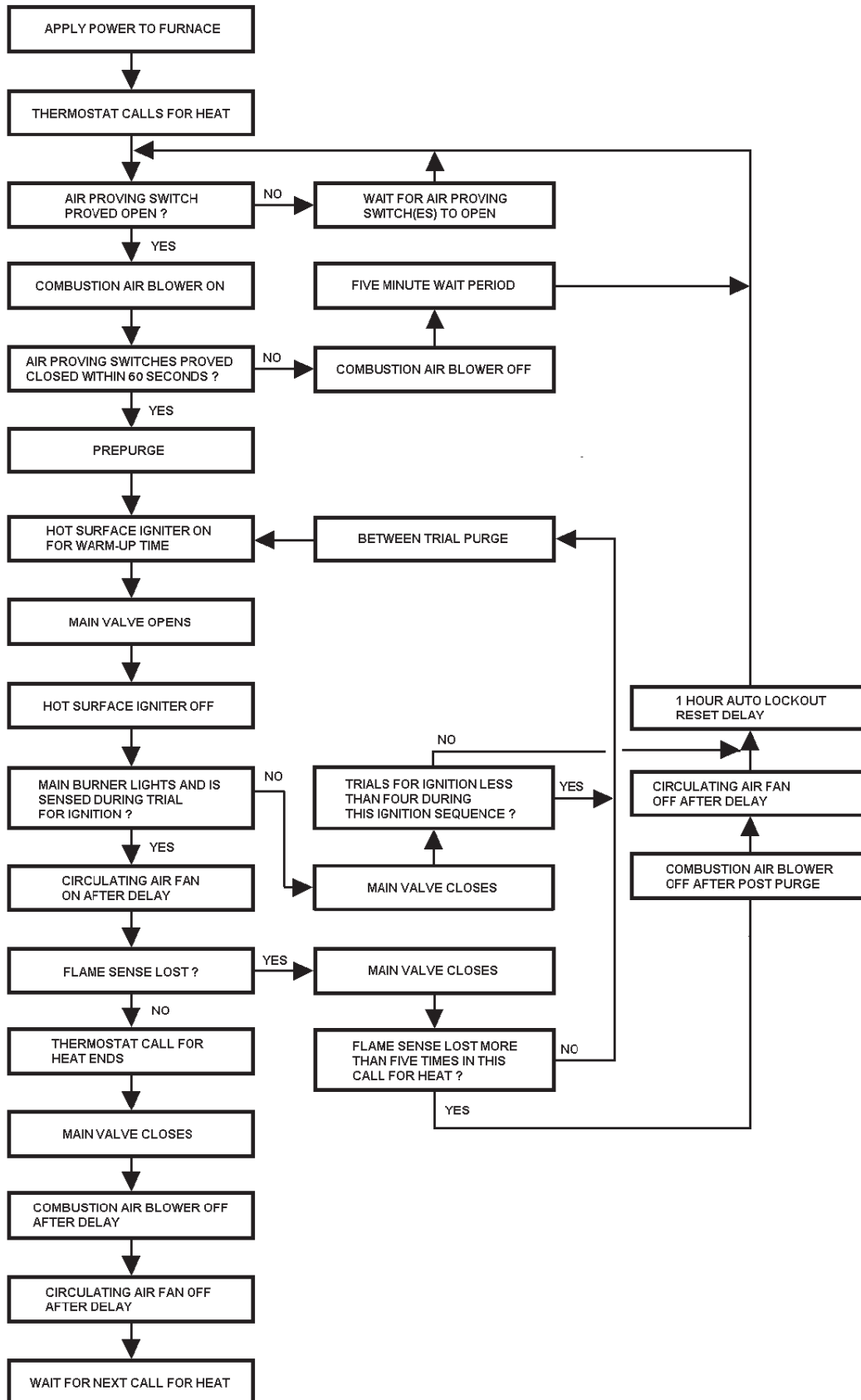

## DIAGNOSTIC CODES FOR STATUS LED

LED Condition	Fault Condition	Diagnostic Check
LED ON	Normal Operation	No action required. Control Okay.
LED OFF	Twin fault or no power	<p>Line voltage input power at L1 and Neutral connectors control board.</p> <p>System wiring harness in good condition and securely connected at both ends.</p> <p>Line voltage removed from one furnace (Twin) and not the other.</p> <p>24 VAC supply to twinned furnaces should be in phase.</p>
Rapid Flash	Internal control fault	
1 Flash	High limit switch open	<p>Open limit switch.</p> <p>Limit switch and wiring in good condition and securely connected.</p> <p>Check for blocked air filter, correct temperature rise, blower speed selection, closed ducts, etc.</p>
2 Flashes	Pressure switch open with inducer on	<p>Pressure switch operation, tubing and wiring.</p> <p>Obstructions or restrictions in venting preventing proper air flow.</p>
3 Flashes	Pressure switch closed with inducer off	<p>Pressure switch stuck closed.</p> <p>Pressure switch mis-wired or jumpered</p>
4 Flashes	Control lockout due to failed ignition	<p>Gas supply OFF, or gas supply pressure too low to operate furnace.</p> <p>Damaged or broken HSI element.</p> <p>Line voltage input power at L1 and Neutral connectors control board.</p> <p>Furnace not properly earth grounded.</p> <p>Flame sensor rod contaminated or in incorrect position.</p> <p>HSI element located in wrong position.</p> <p>Hot surface element or flame sensor wiring in good condition and properly connected.</p>

## DIAGNOSTIC CODES FOR STATUS LED

LED Condition	Fault Condition	Diagnostic Check
5 Flashes	Incorrect line voltage phasing or voltage not present on L1	Check supply voltage to ensure proper polarity to L1 and Neutral connections
6 Flashes	Lockout too many limit switch trips in a call for heat (5)	If the limit switch opens more than 5 times in a single call for heat.  Check for blocked air filter, correct temperature rise, blower speed selection, closed ducts, etc.
7 Flashes	Too many pressure switch dropouts in one call for heat (5)	Pressure switch operation, tubing and wiring.  Obstructions or restrictions in venting preventing proper air flow.
8 Flashes	Too many flame sense losses in 1 call for heat (5)	Check system for proper ground.  Dirty, oxidized or failed flame sensor
9 Flashes	Limit switch open for more than 150 seconds; Hard lockout	Open limit switch.  Limit switch and wiring in good condition and securely connected.  Check for blocked air filter, correct temperature rise, blower speed selection, closed ducts, etc.
10 Flashes	Flame present with gas valve off	Flame at main burner.  Gas Valve
11 Flashes	Rollout switch open	Check flame rollout switch  Ensure wiring is in good condition and securely connected.

## FAULT CODE HISTORY

The control stores the last 5 fault codes in memory. When the pushbutton switch is pressed for less than 5 seconds, the control will flash the stored fault codes when the switch is released. The most recent fault code is flashed first, the oldest last.

Fault history may be cleared by holding the pushbutton switch for more than 5 seconds.

## GENERAL TROUBLESHOOTING

IF	AND	CHECK or REPAIR
Induced blower does not energize when call for heat.	No error code.	<ol style="list-style-type: none"> <li>1. Induced blower wiring.</li> <li>2. Induced blower.</li> <li>3. T-stat defective.</li> </ol>
Induced blower does not energize.	Error code indicating Pressure Switch failure.	<ol style="list-style-type: none"> <li>1. Pressure switch stuck closed.</li> <li>2. Pressure switch is mis-wired or jumpered.</li> </ol>
Induced blower is energized.	Induced blower turns off after 60 seconds.	<ol style="list-style-type: none"> <li>1. Pressure switch stuck open.</li> <li>2. Pressure switch, tubing and wiring. Water in tubing. Reroute tubing to always be above drain hole.</li> <li>3. Obstruction in furnace combustion air intake or exhaust piping.</li> </ol>
Pre-purge time has expired	HSI element does not glow red within 10 seconds.	<ol style="list-style-type: none"> <li>1. Broken or damaged HSI element.</li> <li>2. Broken or damaged HSI element lead-wires.</li> <li>3. Board failure to power HSI element.</li> </ol>
HSI element warm up time has expired and main valve has been energized.	Does not light within trial for ignition period.	<ol style="list-style-type: none"> <li>1. Gas valve did not open.</li> <li>2. Inlet gas pressure too low for main burner ignition.</li> <li>3. Input line voltage too low to heat HSI element.</li> <li>4. HSI element incorrectly positioned.</li> <li>5. Clogged or incorrect main burner orifice.</li> <li>6. Check gas valve on/off switch.</li> </ol>

# 16 - WIRE DIAGRAM FOR PSC MOTOR

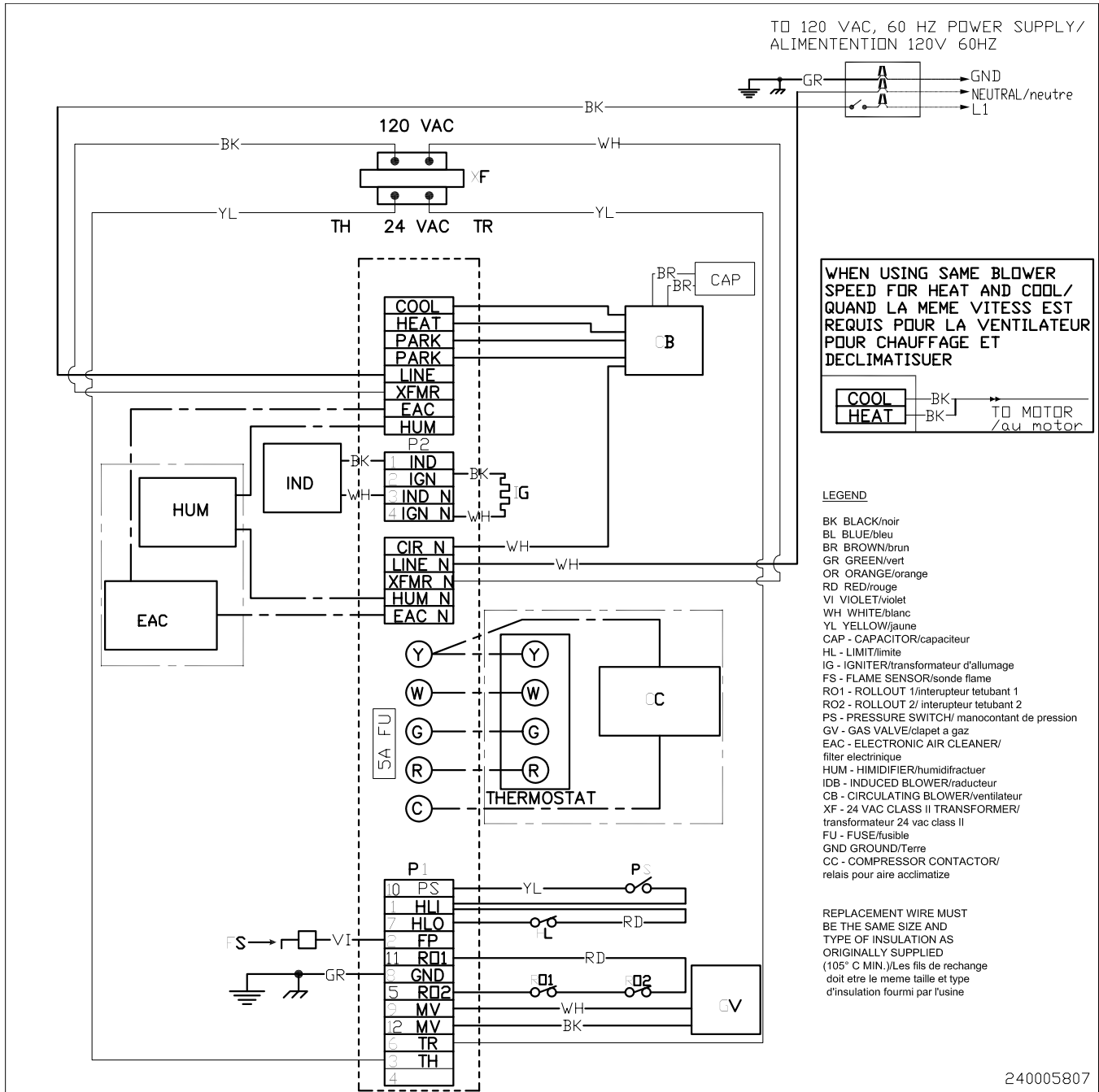

# REPLACEMENT PARTS LIST

## MID EFFICIENT GAS FURNACE

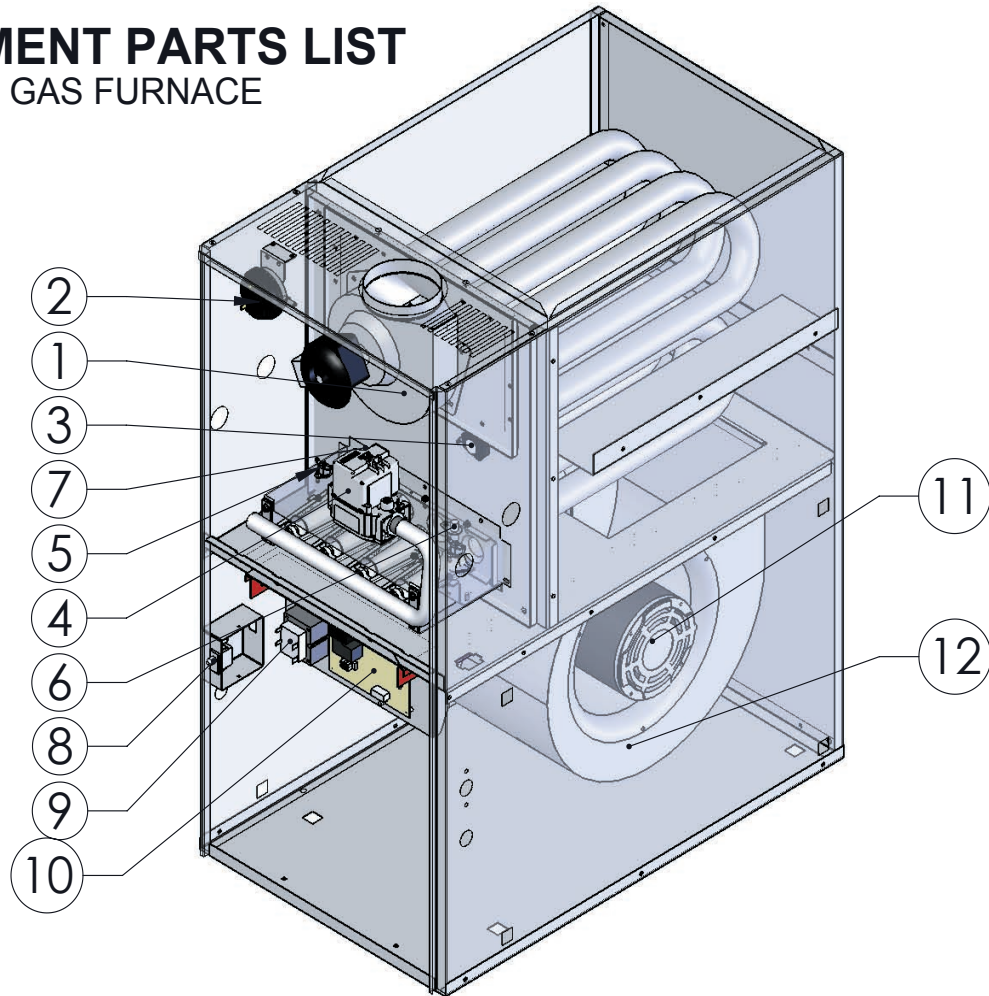

Replacement Parts List

Item	Kit Number	Repair Parts List for Mid Efficient Gas Furnace
1	550001508	KIT,IND,BLW,REPL,MID.
2	550001509	KIT,PRESS,SWITCH MID.
3	550001525	KIT,LIMIT SWITCH 150F (5-TON UNITS ONLY)
3	550001506	KIT,LIMIT SWITCH 180F (3&4 TON UNITS ONLY)
4	550001526	KIT,GAS VALVE
5	550001507	KIT,FLAME ROLLOUT SWITH 300F
6	550001527	KIT,HOT SURF,IGNITOR
7	550001528	KIT,FLAME SENSOR
8	550001532	KIT,DOOR SWITCH
9	550001533	KIT,TRANSFORMER 120V/24V SEC.
10	550001524	KIT,INTEGRATED FURNACE CONTROL BOARD
11	550001529	KIT,1/3HP 3SPD DD MOTOR W/CAPACITOR
11	550001530	KIT,1/2HP 4SPD DD MOTOR W/CAPACITOR
11	550001531	KIT,3/4HP 4SPD DD MOTOR W/CAPACITOR
12	550001511	KIT,BLOWER 10-8 W/WHEEL
12	550001535	KIT,BLOWER 10-10 W/WHEEL
12	550001536	KIT,BLOWER 12-10T W/WHEEL
13*	550001510	KIT,WIRE HARNESS
14*	550001458	KIT,FILTER
15*	550001534	KIT,FUSE 5 AMP.
16*	550001512	KIT,CONV,NG,LP,H/A,MID CAN/US
17*	550001537	KIT,BLOWER HARDWARE 10" DIAMETER
18*	550001538	KIT,BLOWER HARDWARE 12" DIAMETER
19*	550001345	KIT,CONV,NG TO LP MID

\* NOT SHOWN

Replacement Parts List		
Item	Kit Number	Repair Parts List for Mid Efficient Gas Furnace
1	550001508	KIT,IND,BLW,REPL,MID. <i>Jaket induced blower with gasket and termination</i>
2	550001509	KIT,PRESS, SWITCH MID. <i>-0.55 Pressure switch with bracket</i>
3	550001525	KIT,LIMIT SWITCH 150F (5-TON UNITS ONLY)
3	550001506	KIT,LIMIT SWITCH 180F (3&4 TON UNITS ONLY)
4	550001526	KIT,GAS VALVE <i>VR8205S5802B 24V Honeywell K2 gas valve set for NG</i>
5	550001507	KIT,FLAME ROLLOUT SWITH 300F
6	550001527	KIT,HOT SURF,IGNITOR
7	550001528	KIT,FLAME SENSOR
8	550001532	KIT,DOOR SWITCH
9	550001533	KIT,TRANSFORMER 120V/24V SEC.
10	550001524	KIT,INTEGRATED FURNACE CONTROL BOARD
11	550001529	KIT,1/3HP 3SPD DD MOTOR W/CAPACITOR <i>1/3 HP motor 7.5 µf capacitor</i>
11	550001530	KIT,1/2HP 4SPD DD MOTOR W/CAPACITOR <i>1/2 HP motor 10 µf capacitor</i>
11	550001531	KIT,3/4HP 4SPD DD MOTOR W/CAPACITOR <i>3/4 HP motor 20 µf capacitor</i>
12	550001511	KIT,BLOWER 10-8 W/WHEEL
12	550001535	KIT,BLOWER 10-10 W/WHEEL
12	550001536	KIT,BLOWER 12-10T W/WHEEL
13*	550001510	KIT,WIRE HARNESS <i>Wire harness, supply Wire harness, Junction box to Board Wire harness, Board to Blower division Wire harness, Blower division to Safetys Wire harness, Board to Blower Motor</i>
14*	550001458	KIT,FILTER <i>Filter rack Filter rail 16" x 25" permanent filter</i>
15*	550001534	KIT,FUSE 5 AMP.
16*	550001512	KIT,CONV,NG,LP,H/A,MID CAN/US <i>All fuels and altitudes springs and orifices</i>
17*	550001537	KIT,BLOWER HARDWARE 10" DIAMETER <i>48 frame motor mounting band with fasteners 3 - 10" diameter motor mounting arms</i>
18*	550001538	KIT,BLOWER HARDWARE 12" DIAMETER <i>48 frame motor mounting band with fasteners 3 - 12" diameter motor mounting arms</i>
19*	550001345	KIT,CONV,NG TO LP MID <i>LP spring and orifices</i>

\* NOT SHOWN